



Emergency Response Guide



2022.03
V6710BE







SUBARU CORPORATION

Foreword

- This guide provides precautions for emergency responders when handling SUBARU vehicles during an incident.
- It is important to read this guide thoroughly and understand the structure and features of SUBARU vehicles to ensure safety.
- The illustrations used in this guide are representative examples. Refer to the Quick Reference Sheet (QRS) for each model for model specific information such as key identification points, component locations, etc.

Reading this manual

■ Explains symbols used in this manual

Symbols	Meanings
 WARNING	■ Explains something that, if not obeyed, could cause death or serious injury to people.
 NOTICE	■ Explains something that, if not obeyed, could cause damage to or a malfunction in the vehicle or its equipment.
 NOTE	■ Explains things not found in the explanations of functions or operation methods, or other convenient-to-know items.
	■ Indicates a description note for components that are subject to unintended deployment, operation, potential explosions or parts that may fly off.
	■ Indicates a description note for components that may cause electric shock.
	■ Indicates a description note for components that may leak.

Foreword**Reading this manual****Components Requiring Special Attention**

• SRS Airbags	7
Driver Airbag	8
Passenger Airbag	9
Front Knee Airbag	9
Front Seat Side Airbag	10
Front Seat Center Airbag	10
Curtain Shield Airbag	11
• Seatbelt Pretensioner	12
• Gas-filled Damper	13
Front and Rear Suspension Dampers	13
Hatchback Door Dampers	13
• 12 V Battery	14
• Integrated Capacitor	15
• High Voltage System	16
High Voltage Battery	18
High Voltage Power Cable	20
Inverter/Converter	20
DC/DC Converter	21
eAxle (Front)	21
eAxle (Rear)	22
A/C Compressor	22
High Voltage Electric Water Heater	23
Plug-in Charging System	23
ESU (Electricity Supply Unit)	25
• Electric Power Steering (EPS)	26
• Solar Charging System	27
• EC Mirror	29
• Structural Reinforcements	30
Side Impact Protection Beam	30
Ultra High Tensile Strength Sheet	30
• Window Glass	31
Laminated Glass	31
Tempered Glass	31
• Front Seat	32
Manual Seat	32
Power Seat	33

Table of Contents

• Rear Seat	34
Manual Seat	34
• Headrest	35
Manual Headrest	35
• Tilt & Telescopic Steering	36
Manual Tilt & Telescopic	36
• Doors	37

Emergency Response Key Points

• Vehicle Identification	39
Appearance and Logos	39
Frame Number	40
Vehicle Identification Number (VIN)	40
• Immobilize Vehicle	41
Vehicle with High Voltage Battery	43
• Disable Vehicle	44
Vehicle with High Voltage Battery	48
Vehicle with Plug-in Charge System	48
• Stabilize Vehicle	50
• Access Patients	51
Vehicle with High Voltage Battery	51
Cut Vehicle	52
• Fire	53
Fire Extinguisher	53
Vehicle with High Voltage Battery	53
Vehicle with Lithium ion (Li-ion) Battery	53
• Submersion	54
Vehicle with High Voltage Battery	54
• Spills	55
Coolant	55
Traction Battery Coolant	55
Lubrication Oil	55
Brake Fluid	55
Power Steering Fluid	55
Window Washer Fluid	55
12 V Battery Electrolyte	55
Vehicle with High Voltage Battery	56
• Gas Leaks	57
Nitrogen (N2) Gas	57
Refrigerant Gas	57

Damaged Vehicle Handling Key Points

• Towing Damaged Vehicle	59
Parking Lock	59
Steering Wheel Lock	60
Precautions for FWD (Front Wheel Drive) vehicle	60
Precautions for AWD (All Wheel Drive) vehicles	60
Vehicle with High Voltage Battery	61
• Storing a Damaged Vehicle	62
Submerged Vehicle	62
Vehicle with High Voltage Battery	62

Components Requiring Special Attention

- The construction and functions of components requiring special attention during emergency response are described in this section.



SRS Airbags

- When a vehicle receives a strong impact that can cause serious injury to the occupants, the SRS airbags deploy and the seatbelts restrain the occupants to help reduce impact to the body. Refer to the QRS for each model for the type and location of each SRS airbag.

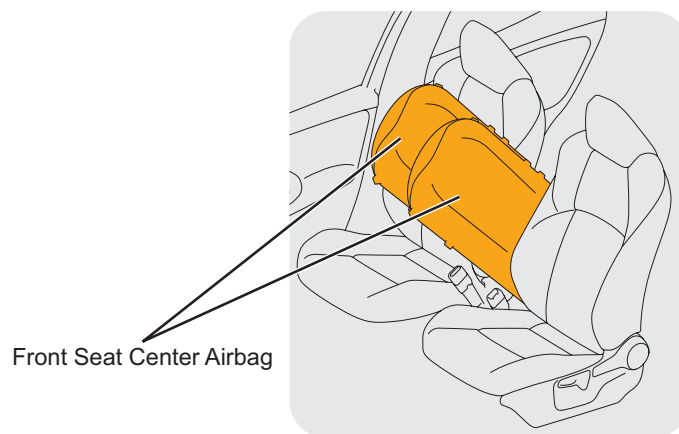
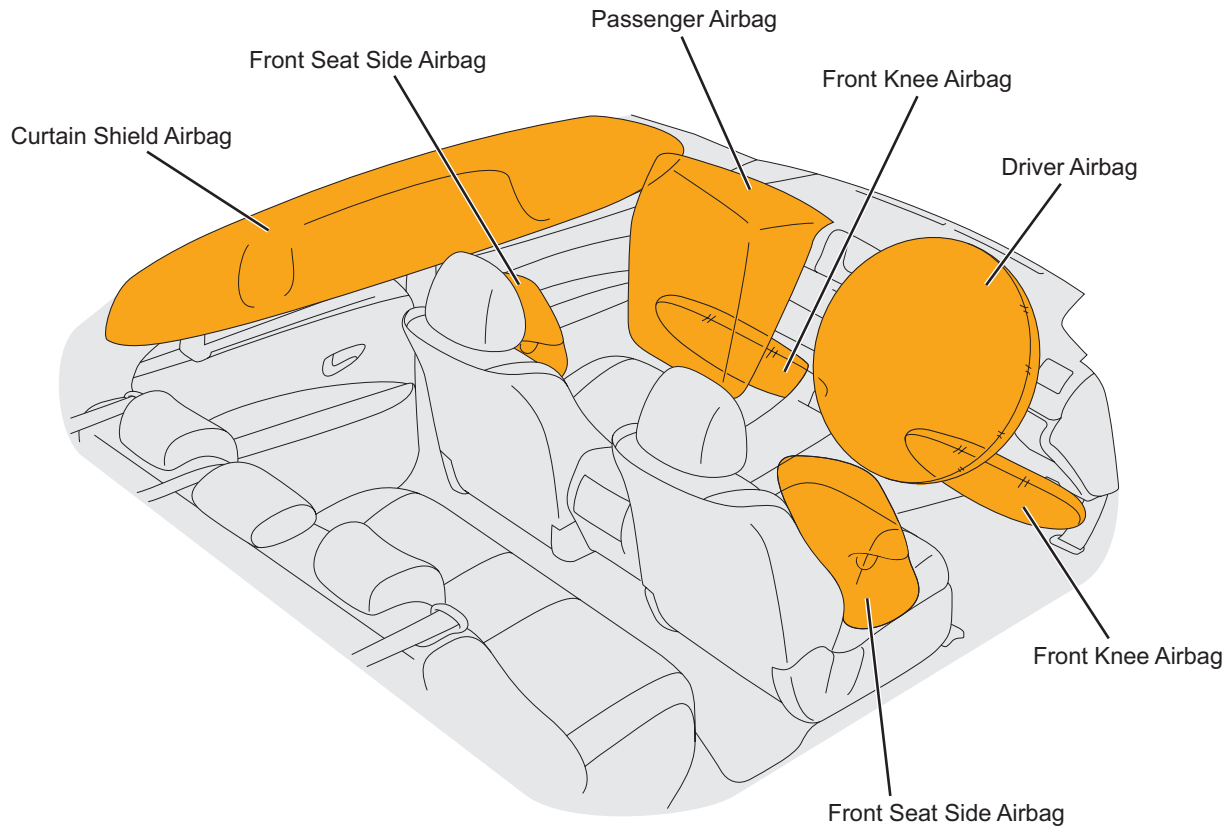

- The SRS airbags consist of an inflator (explosive), a bag and other components and are non-serviceable.
- When an airbag sensor detects a strong impact, an ignition signal is sent to an inflator. When the inflator is ignited, gas is generated to inflate a bag, helping reduce the impact to an occupant.



WARNING

- The SRS airbag may remain powered for up to 90 seconds after the vehicle is shut off and disabled (see page 44). Wait at least 90 seconds before starting any operation. Failure to shut off and disable the vehicle before emergency response procedures are performed may result in serious injury or death from unintentional deployment of the SRS airbag.
- Depending on the circumstances surrounding a collision, such as vehicle speed, point of impact, occupant detection etc., SRS airbags will not always be deployed. If an inflator of the undeployed SRS airbag is breached, the powder inside the inflator may ignite resulting in unintentional SRS airbag deployment. To prevent serious injury or death from unintentional SRS airbag deployment, avoid breaching the inflators.
- Immediately after an SRS airbag is deployed, the components are extremely hot and may cause burns if touched.
- If an SRS airbag deploys with all doors and windows closed, inflation gas may cause breathing difficulty.
- If residue that is produced during SRS airbag deployment comes in contact with skin, rinse it off immediately to prevent skin irritation.

Driver Airbag

- A driver airbag is mounted in the steering wheel pad and activated in the event of a frontal collision.

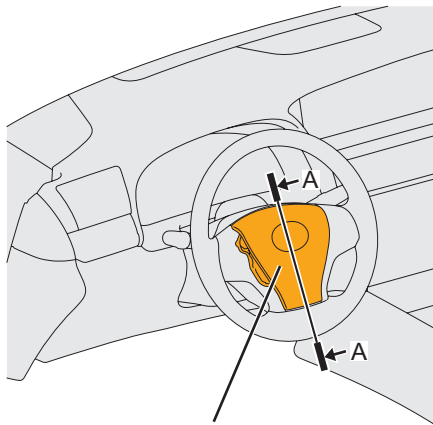

Driver Airbag

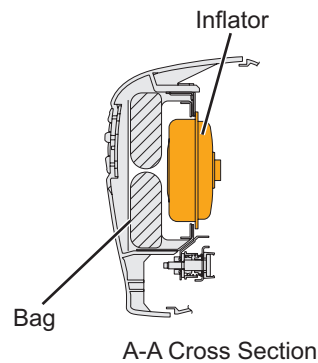

A-A Cross Section



Passenger Airbag

- A passenger airbag is mounted in the upper portion of the passenger side instrument panel and activated in the event of a frontal collision.

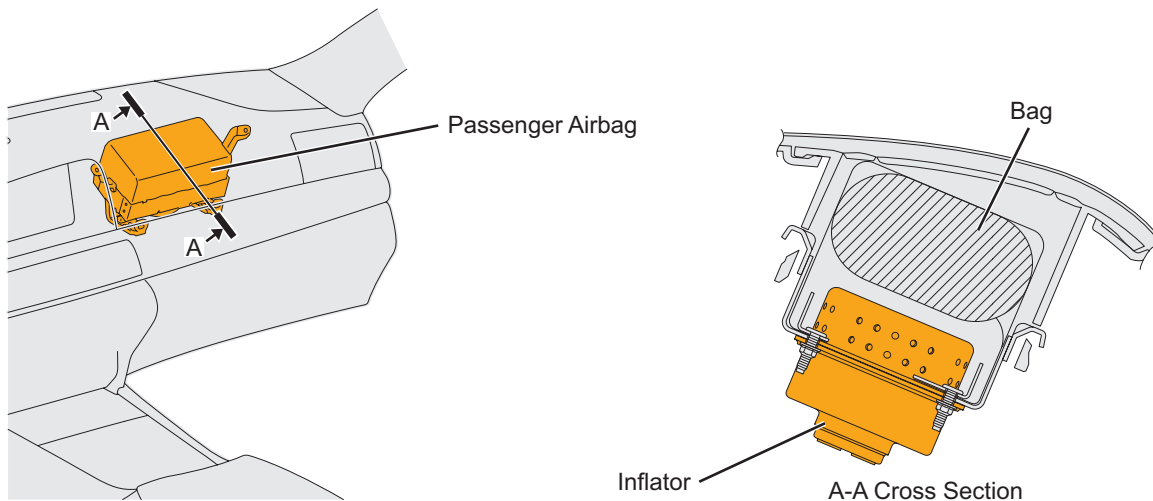

Front Knee Airbag

- Front knee airbags are mounted in the lower portion of the instrument panel on the driver side and the front passenger side, and activated in the event of a frontal collision.

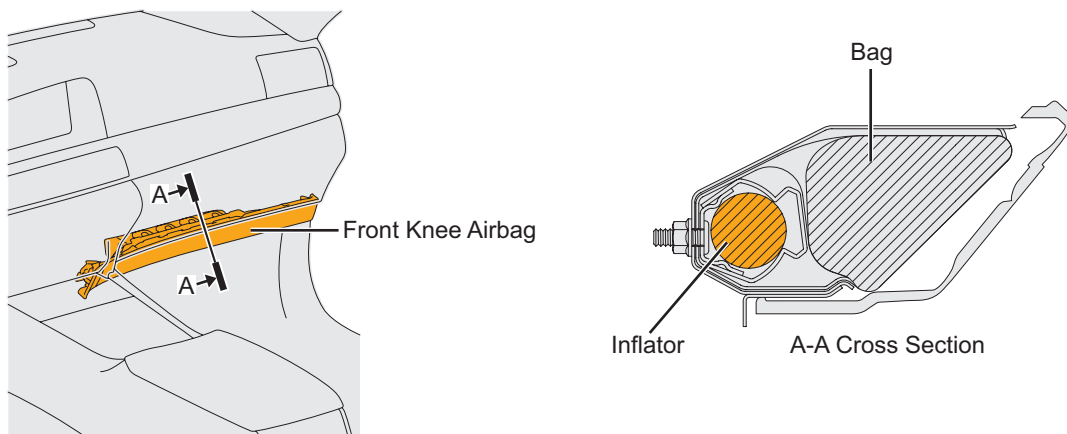



Front Seat Side Airbag

- Front seat side airbags are mounted in the seat frame of the driver seat and the front passenger seat, and activated in the event of a side collision.
- In some vehicles, front seat side airbags are also activated in the event of a frontal collision.

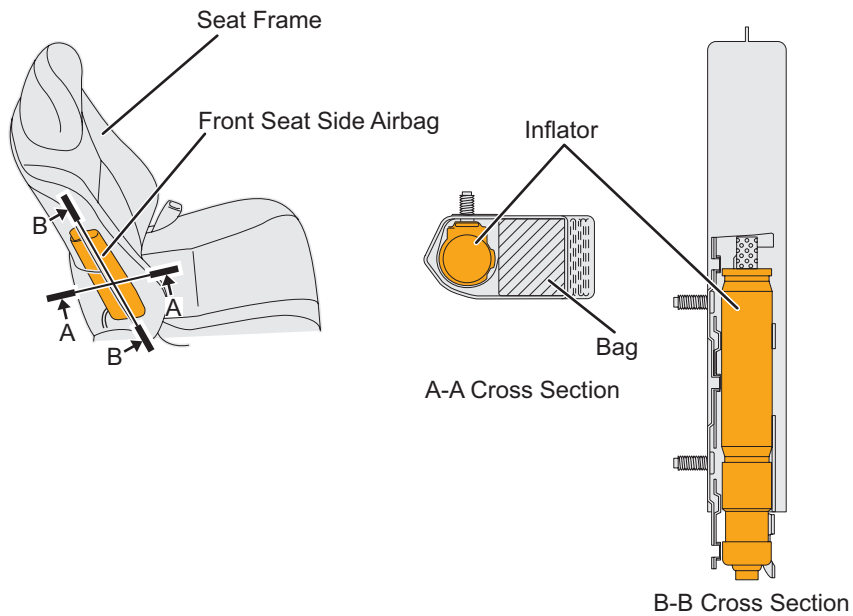

Front Seat Center Airbag

- Front seat center airbags are mounted in the seat frame of the driver seat and the front passenger seat, and activated in the event of a side collision.

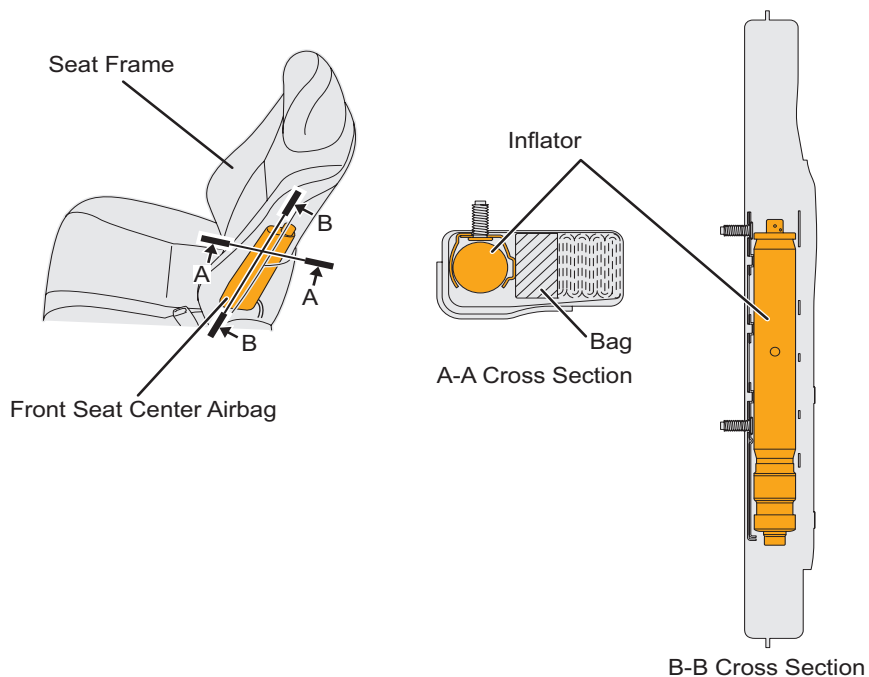



Curtain Shield Airbag

- Curtain shield airbags are mounted in the area between the front pillar and rear pillar on the driver side and the front passenger side, and activated in the event of a side collision.

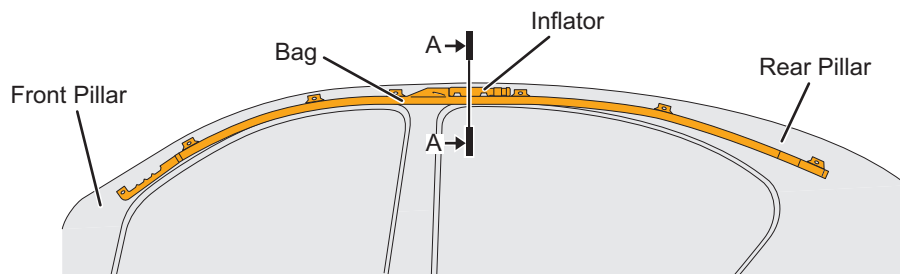

Curtain Shield Airbag

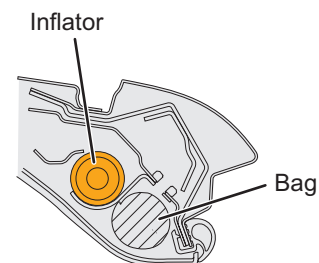

A-A Cross Section



Seatbelt Pretensioner

- When the vehicle receives a strong impact from the front, the seatbelts are retracted to optimally restrain the occupants.
- In some vehicles, seatbelt pretensioners are also activated in the event of a side collision.

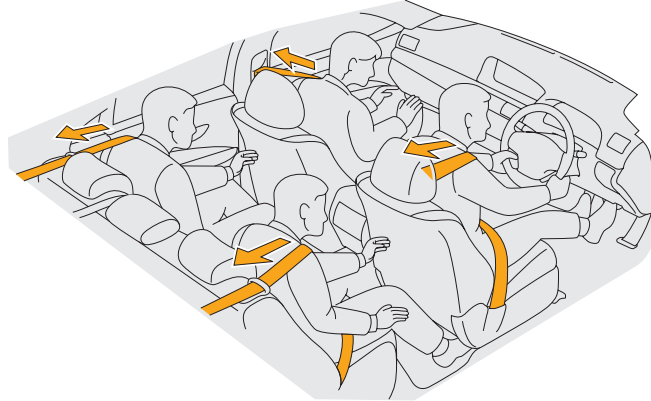

- A pretensioner mechanism is built into the retractor of each of the front, rear seatbelts.
- The pretensioner mechanism consists of a gas generator, a piston and a pinion gear.
- When an airbag sensor detects a strong impact, an ignition signal is sent to a gas generator. When the gas generator is ignited, gas is generated and its pressure rotates a gear that retracts the seatbelt.

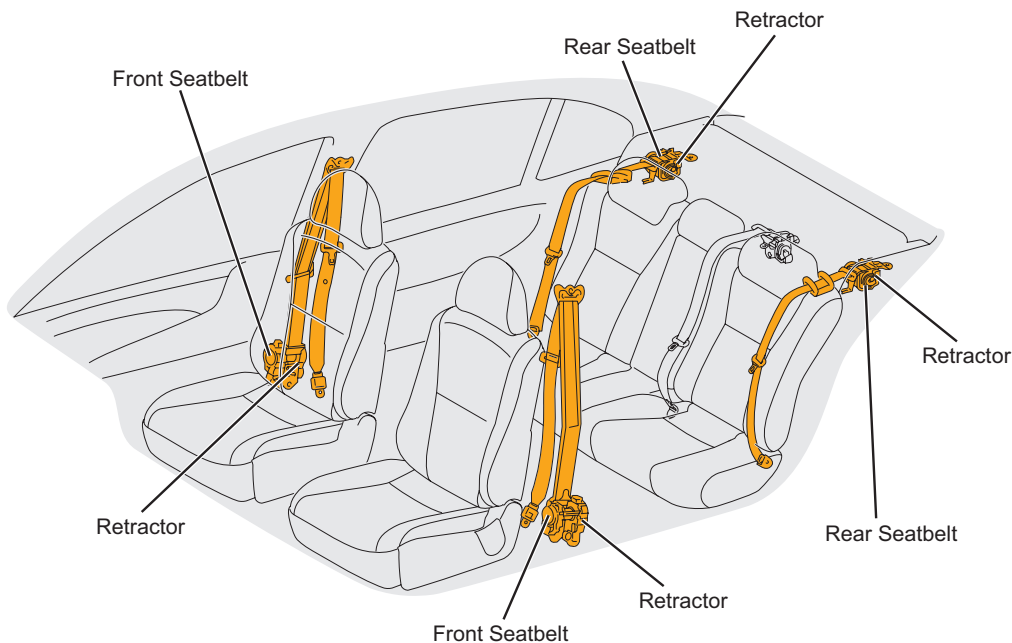

- Refer to the QRS for each model for locations of the seatbelt pretensioners.



- The seatbelt pretensioners may remain powered for up to 90 seconds after the vehicle is shut off and disabled (see page 44). Wait at least 90 seconds before starting any operation. Failure to shut off and disable the vehicle before emergency response procedures are performed may result in serious injury or death from unintentional actuation of the seatbelt pretensioner.
- To prevent serious injury or death from unintentional seatbelt pretensioners actuation, avoid breaching the seatbelt pretensioners.



Gas-filled Damper

- Gas-filled dampers are used in various components, such as in the suspension (shock absorbers), and for other various purposes. Nitrogen (N₂) gas is used in these dampers.
- Nitrogen (N₂) gas is colorless, odorless and harmless.
- Refer to the QRS for each model for the location of these gas-filled dampers.



WARNING

- If a gas-filled damper is heated in an event of a vehicle fire, the damper may explode due to expanded nitrogen (N₂) gas, possibly causing an injury.
- If a gas-filled damper is cut, nitrogen (N₂) gas may cause metal shavings from the cut to scatter. Wear appropriate safety gear such as safety glasses when cutting a gas-filled damper.

Front and Rear Suspension Dampers

- Suspension dampers are installed in the front and the rear suspension.

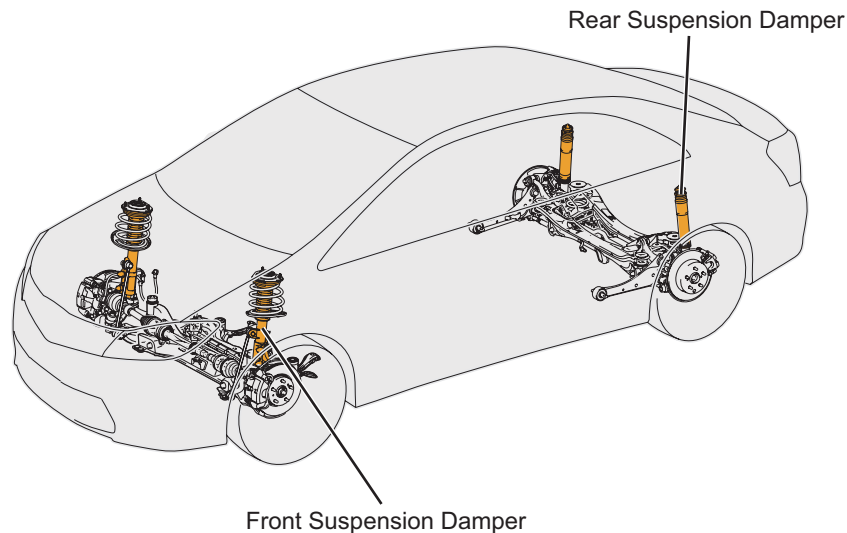

Hatchback Door Dampers

- Gas-filled dampers are installed as the stays for the hatchback door.

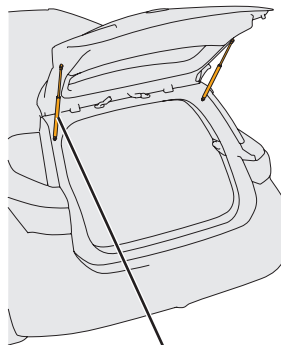

Hatchback Door Damper



12 V Battery

- The 12 V battery supplies power to the ECUs that control various systems and auxiliary components such as the power door lock, power window, power seat, etc.
- To ensure safe emergency response operations, it is necessary to completely shut off the vehicle (see page 44). Disconnect the negative battery terminal from the 12 V battery before performing work and shut off the power to the electrical system to prevent electrical fires and to keep the vehicle from starting.
- 12 V battery electrolyte contains dilute sulfuric acid.
- 12 V battery is installed in the motor compartment.
- Refer to the QRS for each model for locations of the 12 V battery.

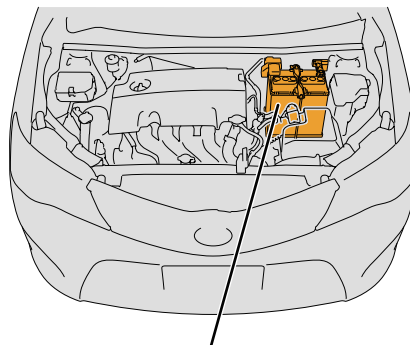

Motor Compartment



WARNING

- There is a possibility of explosion due to ignition of the hydrogen gas generated from the 12 V battery. Therefore, do not allow any open sparks or open flames nearby the 12 V battery.
- Dilute sulfuric acid may cause irritation of the skin if contacted. Wear appropriate protective equipment such as rubber gloves and safety goggles when there is a risk of touching electrolyte.



NOTICE

- Once the 12 V battery is disconnected (see page 44), power controls will not operate. To facilitate emergency response operations, lower the windows, open the back door, unlock the doors and take other necessary actions before shutting off the vehicle.
- 12 V battery electrolyte contains ingredients that damage painted surfaces. If any comes in contact with the vehicle body, discoloration or other damage may occur.



Integrated Capacitor

- The integrated capacitor is installed inside the center console.
- The integrated capacitor operates the electronic shift lever system, remote parking system, etc., even after the auxiliary battery is disconnected.
- By using an internal condenser, the supply of power is ensured.

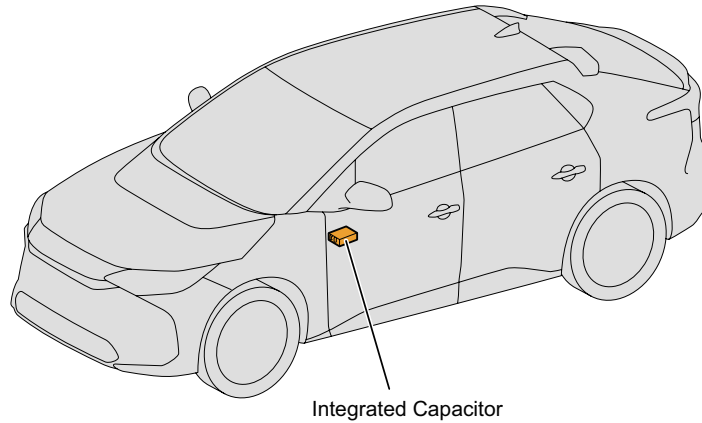

- After the negative (-) terminal of the 12 V battery has been disconnected and the power has been shut off, approximately 12 V is maintained between the positive (+) terminal and negative (-) terminal of the integrated capacitor for up to approximately 10 minutes.



High Voltage System

- Electric vehicles use a motor driven by high voltage electricity (120V - 800V) to generate the driving torque. This vehicle is equipped with high voltage electrical components such as a high voltage battery, inverter/converter, e transaxle, A/C compressor, charger and voltage inverter as well as high voltage power cables.
- High voltage electrical components can be indicated by markings on their case/cover. High voltage power cables are indicated by an orange color.
- The cases/covers of the high voltage electrical components are insulated from the high voltage conductors inside the components. The vehicle body is insulated from the high voltage electrical components, and is safe to touch during normal conditions.
- The READY indicator in the combination meter turns on while the high voltage system is operating.

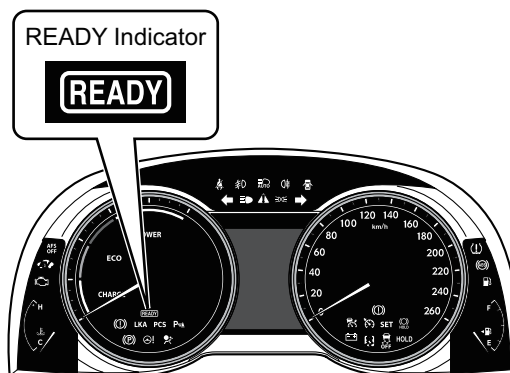

- The high voltage system is deactivated when the power switch is turned OFF. If an impact is detected (SRS airbag is activated) or if a high voltage leakage is detected, the high voltage system is automatically deactivated. When the high voltage is shut off, the READY indicator turns off. However, if the plug-in charging system are being used, even if the READY indicator turns off, the high voltage system may still be active.
- Refer to the QRS for each model for the locations of the high voltage electrical components.



- The high voltage system may remain charged for up to 10 minutes after the vehicle is shut off and disabled (see page 44). Failure to shut off and disable the vehicle before emergency response procedures are performed may result in serious injury or death from severe burns and electric shock from the high voltage electrical system.
- To prevent serious injury or death from severe burns or electric shock, avoid touching, cutting, or breaching any orange high voltage power cable or high voltage component. Wear appropriate protective equipment such as insulated gloves when there is a risk of touching high voltage power cables or high voltage components.
- When the person(s) in charge of handling the damaged vehicle is away from the vehicle, other person(s) may accidentally touch the vehicle and be electrocuted, resulting in severe injury or death. To avoid this danger, display a "HIGH VOLTAGE DO NOT TOUCH" sign to warn others (print and use page 17 of this guide).



Person in charge:

CAUTION:
HIGH-VOLTAGE
DO NOT TOUCH.

CAUTION:
HIGH-VOLTAGE
DO NOT TOUCH.

Person in charge:

When performing work on the HV system, fold this sign and put it on the roof of the vehicle.



High Voltage Battery

- The high voltage battery for the motor stores high voltage electricity (120 to 800 V). Depending on the model the battery is installed in the luggage compartment, under the rear seats, under the center console or under the floor.

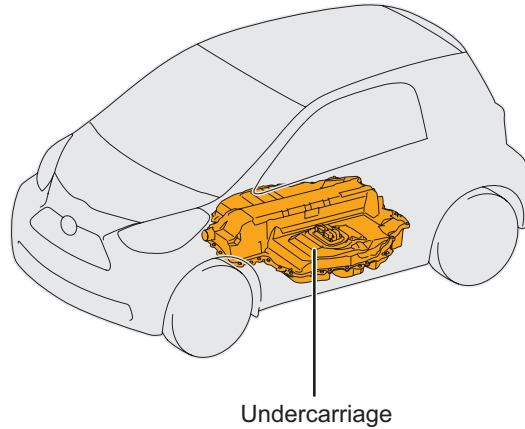

- An under-hood label shows the location of the high voltage battery.

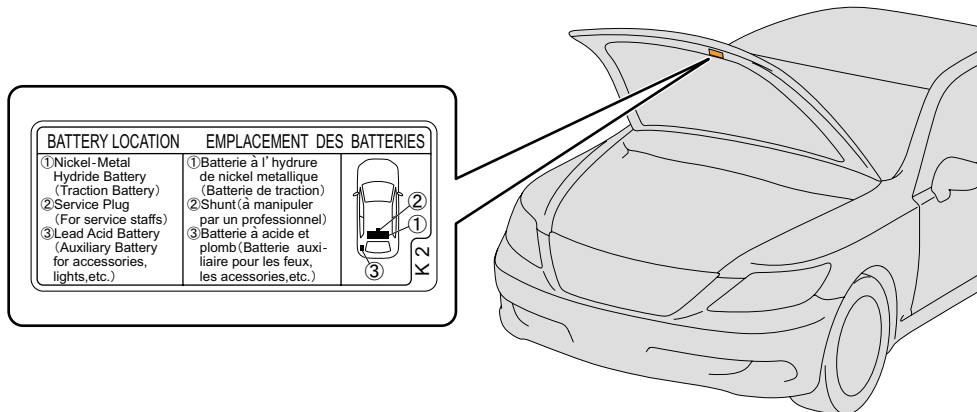



■ A Lithium ion (Li-ion) battery is used as the high voltage battery.

Lithium ion (Li-ion) battery

- Li-ion batteries consist of multiple stacks. Each stack consists of multiple cells, and the stacks are connected in series to obtain high voltage (120 to 800 V).
- The battery cells are sealed in a case and cannot easily be touched.
- A catastrophic crash that would breach both the metal battery stack case or battery frame and a metal battery cells would be a rare occurrence.
- The Li-ion battery electrolyte, mainly consisted of carbonate ester, is a flammable organic electrolyte. The electrolyte is absorbed into the battery cell separators, even if the battery cells are crushed or cracked, it is unlikely that liquid electrolyte will leak.
- Any liquid electrolyte that leaks from a Li-ion battery cell quickly evaporates.

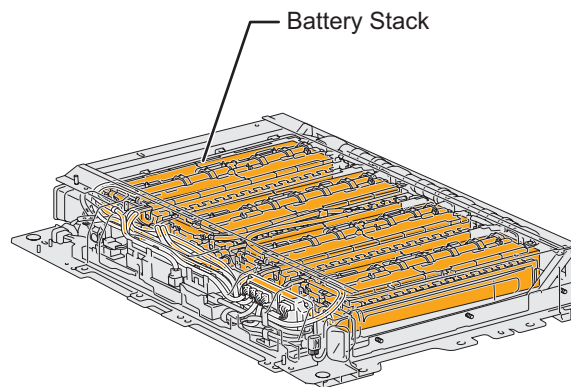

WARNING

- The flammable organic electrolyte which primarily contains carbonate ester is harmful to the human body. In case of contact with the electrolyte, it may irritate the eyes, nose, throat and skin. In case of contact with the smoke or vapor from leaked electrolyte or a burning battery, it may irritate the eyes, nose or throat. To avoid injury by coming in contact with the electrolyte or vapor, wear appropriate protective equipment such as rubber gloves, safety goggles, protective mask or SCBA when there is a risk of touching electrolyte.
- If the electrolyte spills, keep it away from fire and ensure the area is well ventilated. Absorb the electrolyte with a waste cloth or equivalent absorbing material and keep it in an airtight container until disposed of.



High Voltage Power Cable

- High voltage power cables are indicated by an orange color and are used to connect high voltage electrical components such as the high voltage battery inverter/converter, electric motor, A/C compressor and charger.
- The high voltage power cables are installed in the motor compartment and in the center of the vehicle (routed through the center tunnel).
- Also, high voltage cables are used in the plug-in charging system (see page 23) and the solar charging system (see page 27).

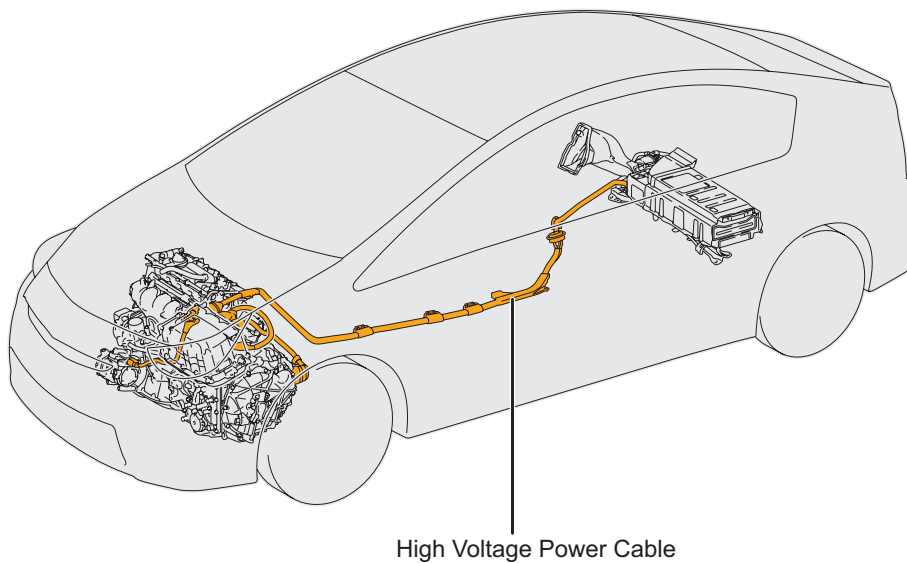

Inverter/Converter

- The inverter/converter installed in the e transaxle boosts and inverts the DC electricity from the high voltage battery to AC electricity that drives the electric motor.

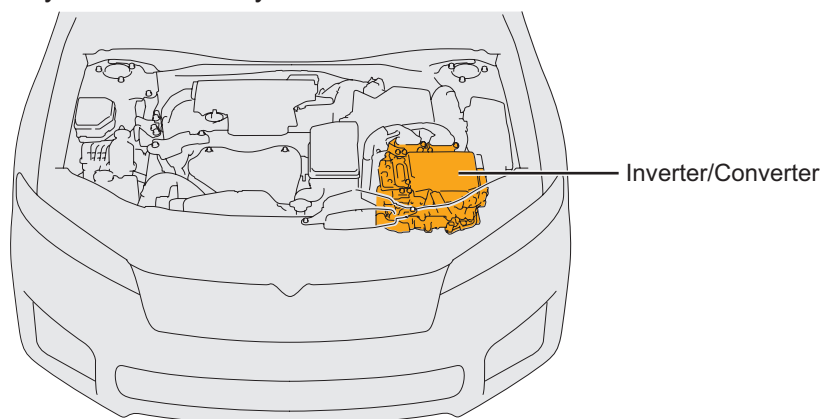



DC/DC Converter

- The DC/DC converter lowers the DC electricity from the high voltage battery to supply it to electric accessories such as the headlights and power windows, and to charge the 12 V battery.

DC/DC Converter (Built into Inverter/Converter)

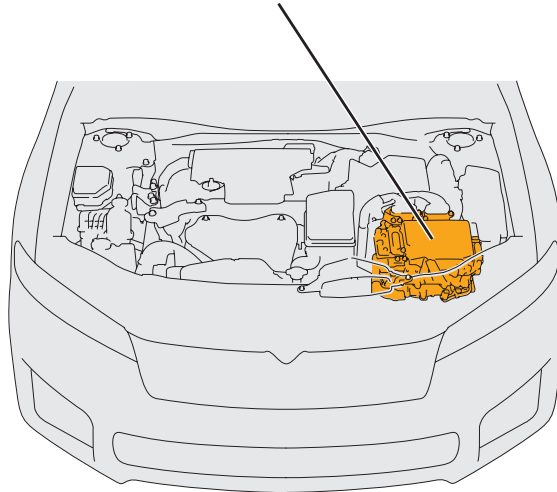

eAxle (Front)

- eAxle (Front) contains an electric motor/generator that is powered by output voltage (up to 650 V) from the inverter/converter, and charges the high voltage battery.
- eAxle (Front) is installed in the motor compartment.

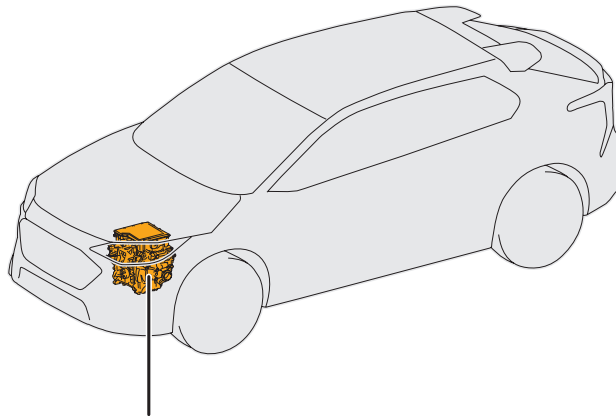

eAxle (Rear Electric Motor (Traction Motor))



eAxle (Rear)

- The eAxle (Rear) is powered by output voltage (up to 650 V) from the inverter/converter.
- It is built into the rear transaxle and located above the rear driveshafts.

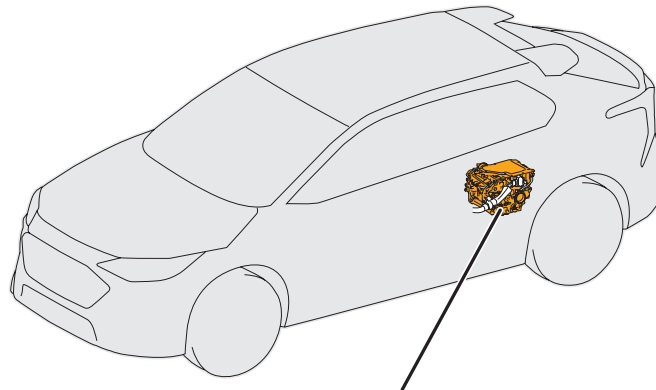

eAxle (Front Electric Motor (Traction Motor))

A/C Compressor

- The A/C compressor used on electric vehicles contains an electric motor that is powered by electricity from the high voltage battery. It is installed in the motor compartment.

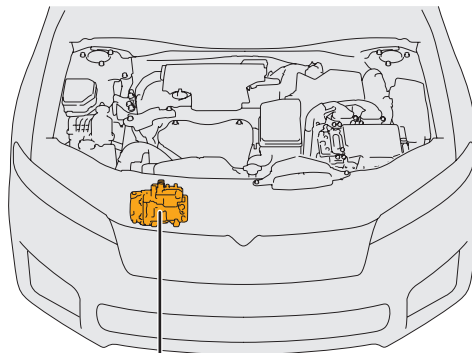

A/C Compressor



High Voltage Electric Water Heater

- The motor compartment of the electric vehicle is equipped with a high voltage electric water heater which heats the coolant.
- The high voltage electric water heater is operated using voltage from the high voltage battery.
- It is operated in the low temperature region when it is difficult to ensure heating performance.

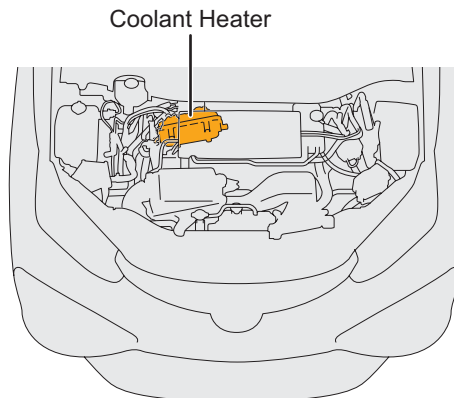

Plug-in Charging System

- Electric vehicles are equipped with a plug-in charging system in order to charge the high voltage battery from an external power source.
- The plug-in charging system is mainly comprised of an onboard charger and charging inlet.
- The onboard charger converts the AC supplied from an external power source to DC, boosts it, and then uses it to charge the high voltage battery.
- The charger inlet receives the charge to the high voltage battery from an external power source. Also, electric vehicles have a separate fast charging inlet which can be used at fast chargers (DC 500 V).
- The orange power cables are connected to the charging inlet, which is supplied high voltage during charging.

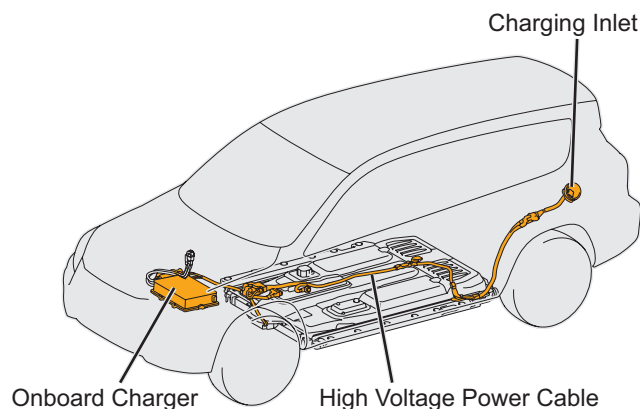



WARNING

- To prevent serious injury or death from severe burns or electric shock, shut off the utility circuit supplying power to the charge cable before disconnecting it if the vehicle, charge cable or charger is submerged in water.



NOTICE

- Electric vehicles have a connector locking system.
- If the lock of the charge cable assembly connector cannot be released, turn OFF or unplug the external charger, or turn its main breaker OFF.

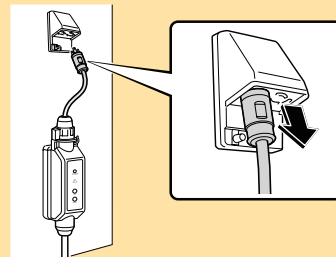
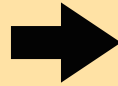
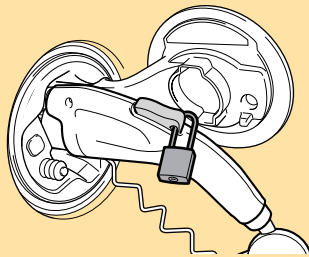

- The lock of the charge cable assembly connector cannot be released during fast charging. If charging does not stop even when the charger is turned OFF, turn its main breaker OFF.



ESU (Electricity Supply Unit)

- An ESU (Electricity Supply Unit) is used which packages the power converter necessary for electric vehicles, and the components traditionally built into the high voltage battery (high voltage junction box, DC relay) into one unit.
- A 2 layer construction is used with the upper layer containing the high voltage junction box, charging inverter ECU and DC relay, and the lower layer containing the DC/DC converter and AC charger.

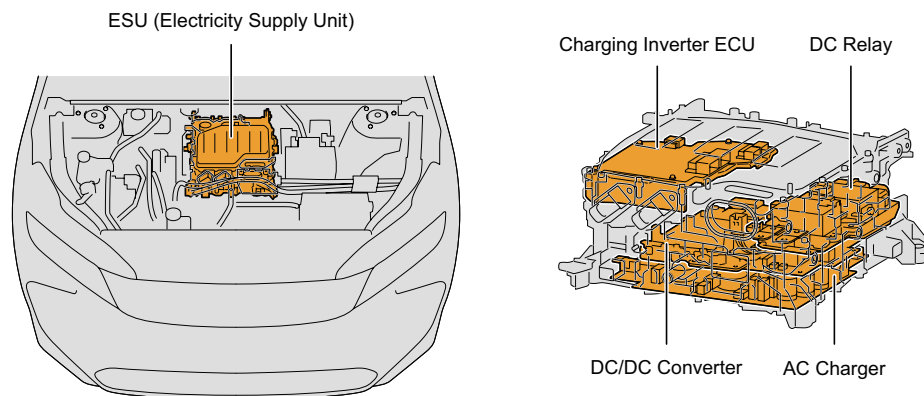

- To prevent electric shock, after disconnecting the high voltage connector, wait for at least 10 minutes before touching any of the high-voltage connectors or terminals.



Electric Power Steering (EPS)

- The Electric Power Steering (EPS) system uses 12 V voltage which has been boosted to up to 46 V by the EPS ECU to drive an EPS assist motor.
- The EPS assist motor is built into the steering gear box.
- A wire which conducts up to 46 V connects the EPS ECU in the motor compartment to the EPS assist motor.

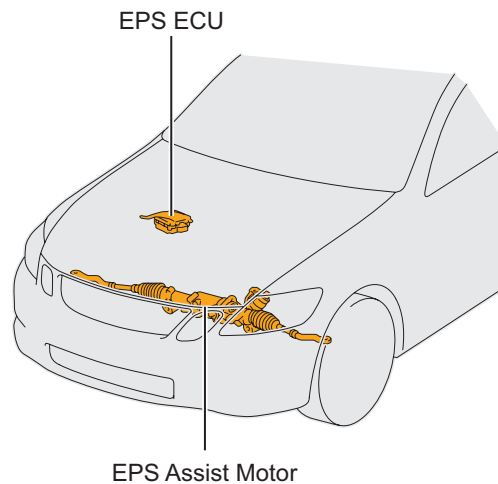



Solar Charging System

- The solar charging system uses a solar roof with an integrated solar cell to generate photovoltaic power which is then used to charge the high voltage battery according to the vehicle condition while parked and to compensate for the consumption of the 12 V battery system while the vehicle is being driven. In addition, the solar charging system charges and discharges the solar battery during this process.
- The solar charging system consists of a solar roof, a solar battery, a solar energy control unit, a high voltage battery and a 12 V battery.
- The orange high voltage power cable is connected between the solar energy control unit and high voltage battery. High voltage is applied when the high voltage battery is charging.
- The solar energy control unit has 3 built-in DC-DC converters: for the high voltage battery, solar battery and auxiliary system.
- A 15 A fuse is used to prevent a dangerous situation even if there is a large flow of current.
- The high voltage battery is not charged except for when the power switch is off.
- Depending on conditions such as solar radiation and temperature, the solar roof can reach a maximum voltage of approximately 50 V.
- Refer to the QRS for each model for the locations of the high voltage electrical components.

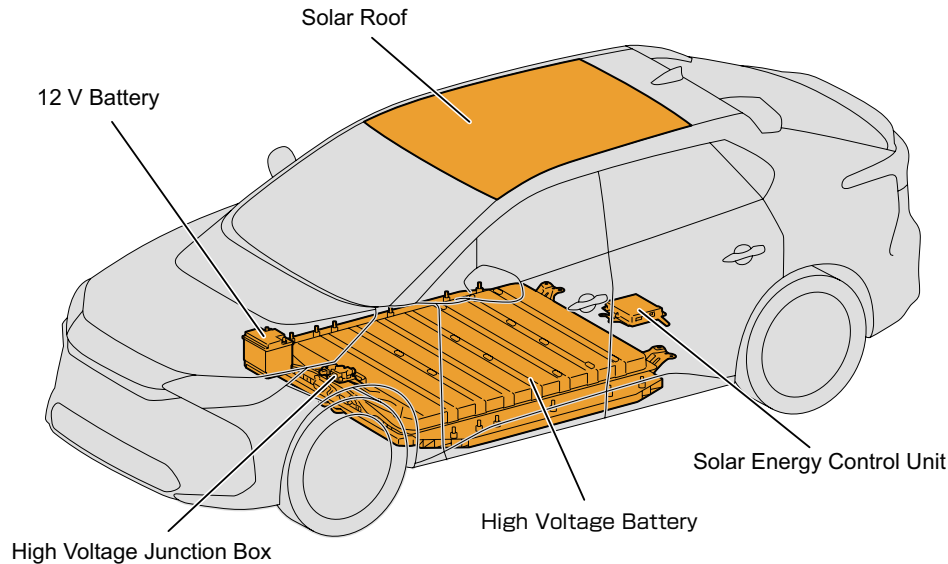

Solar Charging System



WARNING

- The high voltage system may maintain the voltage even when the vehicle is stopped (see page 44) due to the solar charging system. If the high voltage system is not stopped, the high voltage may lead to severe burns or electric shock and may result in death or serious injury.
- To prevent death or serious injury from severe burns or electric shock, avoid touching, cutting, or breaching any orange high voltage power cable or high voltage component. Wear appropriate protective equipment such as insulated gloves when there is a risk of touching high voltage power cables or high voltage components.
- When the person(s) in charge of handling the damaged vehicle is away from the vehicle, other person(s) may accidentally touch the vehicle and be electrocuted, resulting in death or serious injury. To avoid this danger, display a “HIGH VOLTAGE DO NOT TOUCH” sign to warn others (print and use page 17 of this guide).
- The high voltage battery may be charged even when the vehicle is stopped. To stop the high voltage battery from charging, remove the negative (-) terminal of the 12 V battery.
- The solar roof generates electricity with even a small amount of sunlight. To stop generation of electricity, cover the solar roof completely with a material that will block sunlight.
- Strong alkaline electrolyte (pH 13.5) is harmful to the human body. To avoid injury by coming in contact with the electrolyte, wear appropriate protective equipment such as rubber gloves and safety goggles when there is a risk of touching electrolyte.



EC Mirror

- The inner rear view mirror has an auto glare-resistance function, which automatically changes the reflection rate of the mirror. This is done by controlling voltage applied to an electrochromic gel inside the mirror, according to the brightness sensed by a light sensor.

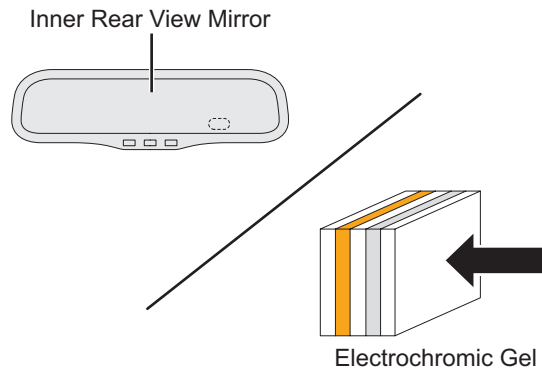

- The electrochromic gel contains organic solvents.



- Organic solvents may cause irritation of the skin if contacted. Wear appropriate protective equipment such as rubber gloves and safety goggles when there is a risk of touching electrochromic gel.

Structural Reinforcements

- A side impact protection beam and ultra high tensile strength sheet steel that are stronger than normal steel sheets are used as structural reinforcements.
- Refer to the QRS for each model for locations of the side impact protection beams and ultra high tensile strength sheet steel.



- Because the strength of side impact protection beam and ultra high tensile strength sheet steel is higher than sheet steel and high tensile strength sheet steel, it is difficult to cut through side impact protection beam and ultra high tensile strength sheet steel with conventional cutters. Avoid side impact protection beam and parts made from ultra high tensile strength sheet steel when cutting a vehicle.

Side Impact Protection Beam

- Side impact protection beams are located inside the door.

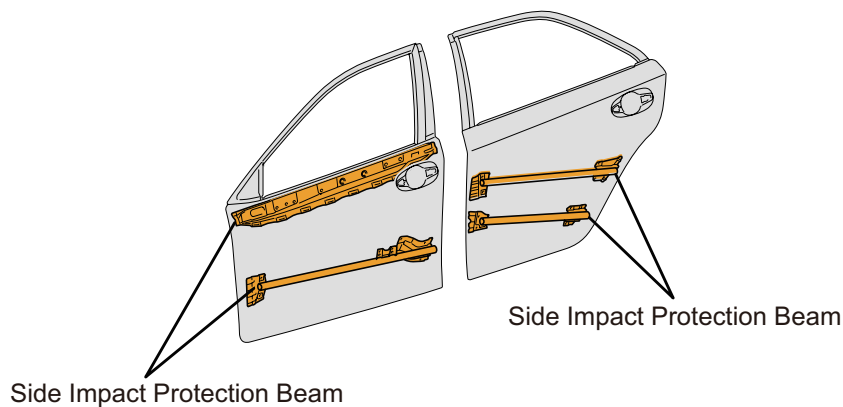

Ultra High Tensile Strength Sheet

- Ultra high tensile strength sheet steel, which is approximately 1.5 times higher strength (1.5 GPa (15,296 kgf/cm², 217,557 psi) class) than standard high tensile strength sheet steel (under 1 GPa (10,197 kgf/cm², 145,038 psi) class), is used for some body structural components on certain models.

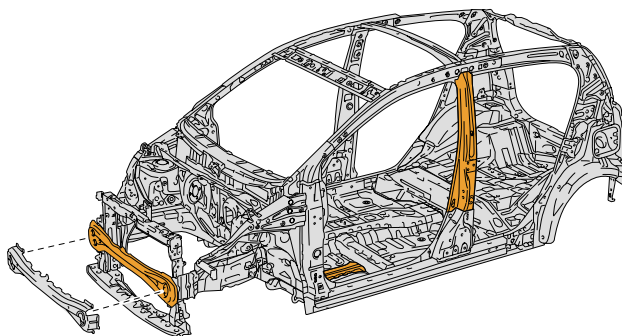

 : Ultra High Tensile Strength Sheet

Window Glass

- Laminated glass and tempered glass are widely used for vehicle windows.
- Tempered glass is mainly used for the door glass, the roof glass and the back window glass.

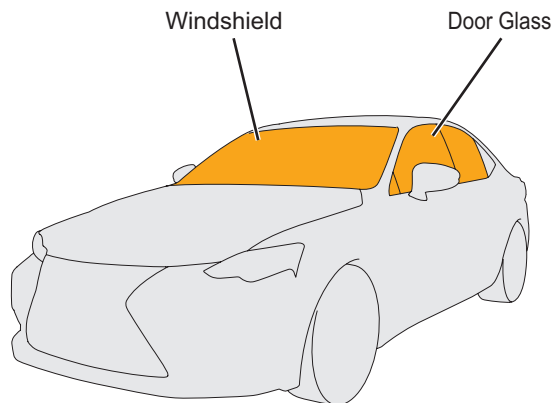

Laminated Glass Applications

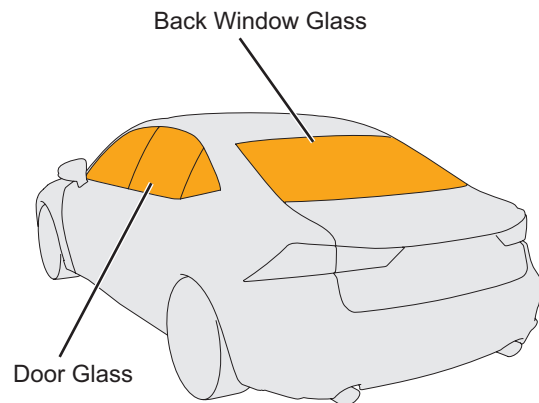

Tempered Glass Applications

- Laminated glass and tempered glass are indicated respectively by “LAMISAFE” or “TEMPERLITE” printed on glass.

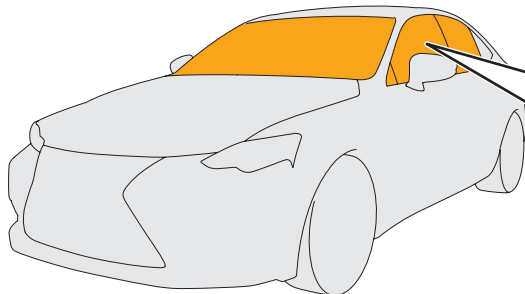

<p>LAMISAFE LP ASAHI M 375 ASI DOT-20</p>	<p>TEMPERLITE TP ASAHI M2L3 S AS3 DOT-20</p>
--	---

Laminated Glass

- Laminated glass consists of 2 layers of glass with a film in-between. Objects that strike the glass are less like to penetrate the glass and glass shards tend to remain adhered to the film.

< LAMISAFE Structure >

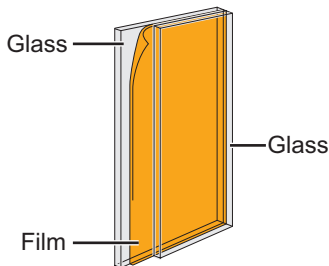

< Broken Laminated Glass >



Tempered Glass

- Tempered glass is heated to near softening temperature, then rapidly cooled down to make it 3 to 5 times stronger than normal glass. When tempered glass is broken, it will break into very small pieces.



NOTICE

- Laminated glass consists of 2 layers of glass bonded together with a film. It does not break easily even when struck by an object.

Front Seat

- Two types of front seats, a manual seat and a power seat, are available. When adjusting the seat position, a lever or a knob is operated for the manual seat and a switch is operated for the power seat.

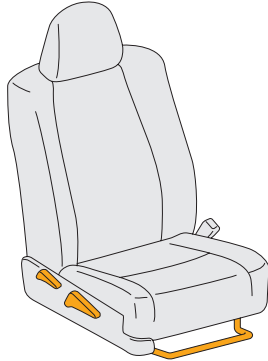

Manual Seat

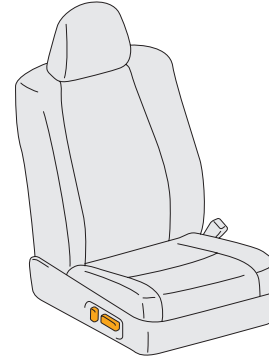

Power Seat

Manual Seat

- The seat can be moved forward/backward by lifting the slide lever (slide adjustment).
- The seatback can be tilted forward/backward by lifting the reclining lever (reclining adjustment).
- The seat cushion can be raised/lowered by repeatedly pulling up/pushing down on the lever (lifter adjustment).

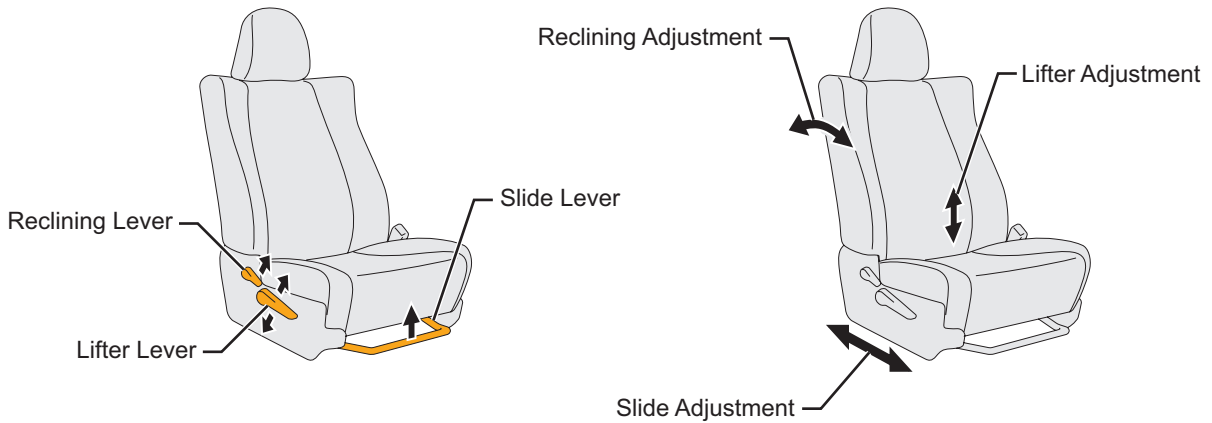

Front Seat

Power Seat

- The seat can be moved forward/backward using the slide function of the power seat switch (slide adjustment).
- The entire seat cushion can be raised/lowered using the lifter function of the power seat switch (lifter adjustment).
- The seatback can be tilted forward/backward by operating the reclining adjustment switch (reclining adjustment).
- The lumbar support position can be moved forward/backward by operating the lumbar support adjustment switch (lumbar support adjustment).

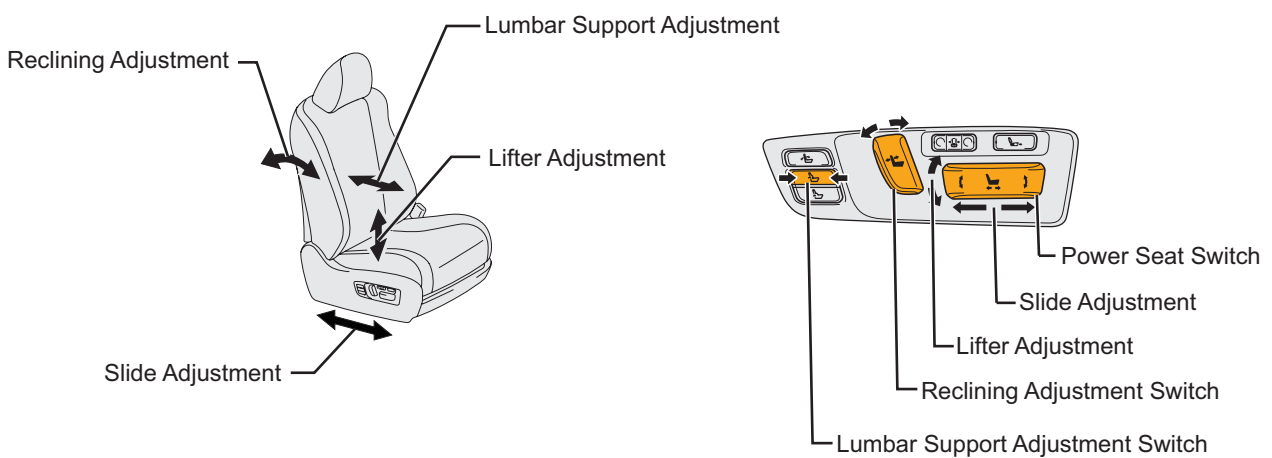

NOTICE

- The seat position adjustment functions of a power seat will be disabled when the 12 V battery is disconnected.

Rear Seat

- Two types of rear seats, a manual seat and a power seat, are available. When adjusting the seat position, a lever or a knob is operated for the manual seat and a switch is operated for the power seat.

Manual Seat

- The seatback can be tilted forward/backward by lifting the reclining lever (reclining adjustment).

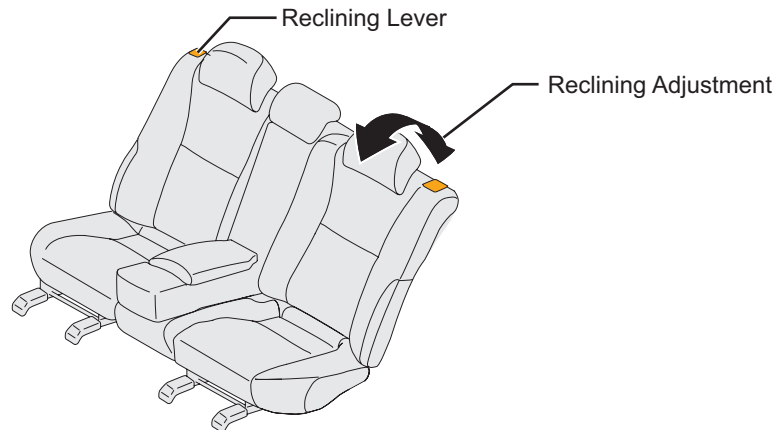

Headrest

- The position of the headrests can be adjusted vertically.

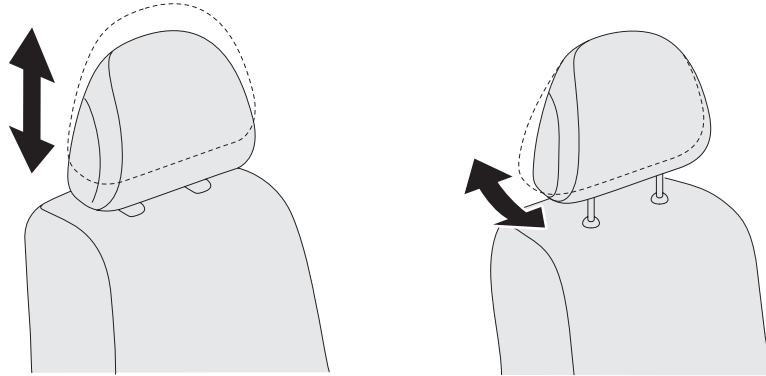

Manual Headrest

- When raising a manual headrest, pull up the headrest by hand. When lowering, push down the headrest while pushing the release button. To remove the headrest, pull out the headrest while pushing the release button.

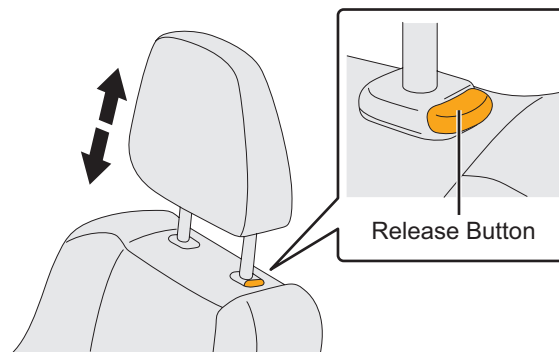

Tilt & Telescopic Steering

- The steering column has a tilt mechanism, which enables vertical adjustment of the steering wheel position, and a telescopic mechanism, which enables horizontal adjustment of the steering wheel position.
- Two types of tilt & telescopic steering, manual tilt & telescopic steering and power tilt & telescopic steering, are available. When adjusting the position of the steering wheel, a lever is operated for the manual tilt and telescopic mechanisms and a switch is operated for the power tilt and telescopic mechanisms.

Manual Tilt & Telescopic

- The manual tilt & telescopic steering is provided with a lock lever under of steering column for releasing the lock when adjusting the steering wheel position.
- When the lock lever is operated, the lock is released, allowing adjustment of the steering wheel position. After adjustment, the steering wheel can be locked in the desired position by returning the lock lever.

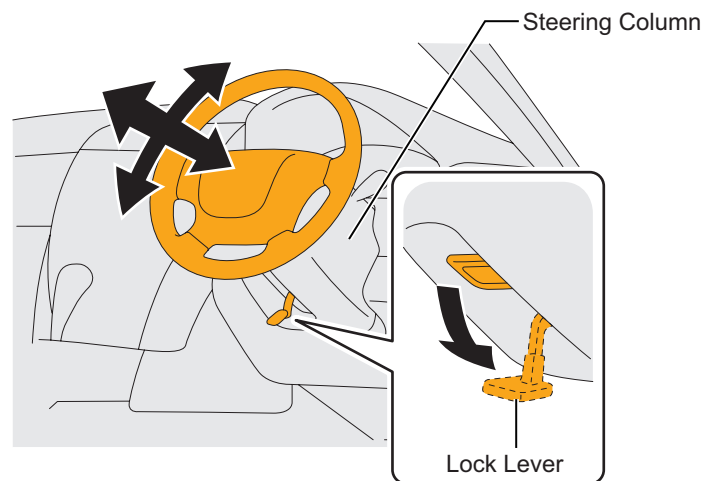

Doors

- The door is opened by operating the handle on the door.

Emergency Response Key Points

- Procedures and points to be noted when handling SUBARU vehicles during emergency response are provided in this section.
- Refer to the Quick Reference Sheet (QRS) for each model for model specific information such as vehicle identification points, component locations, etc.

Vehicle Identification

Appearance and Logos

- Identify the vehicle type based on exterior features and logos on the body.
- Logo marks represent the make, model, grade, and the vehicle type if it uses a high voltage electrical system.
- Logo marks are attached to the trunk lid, back door/hatch and front grille.

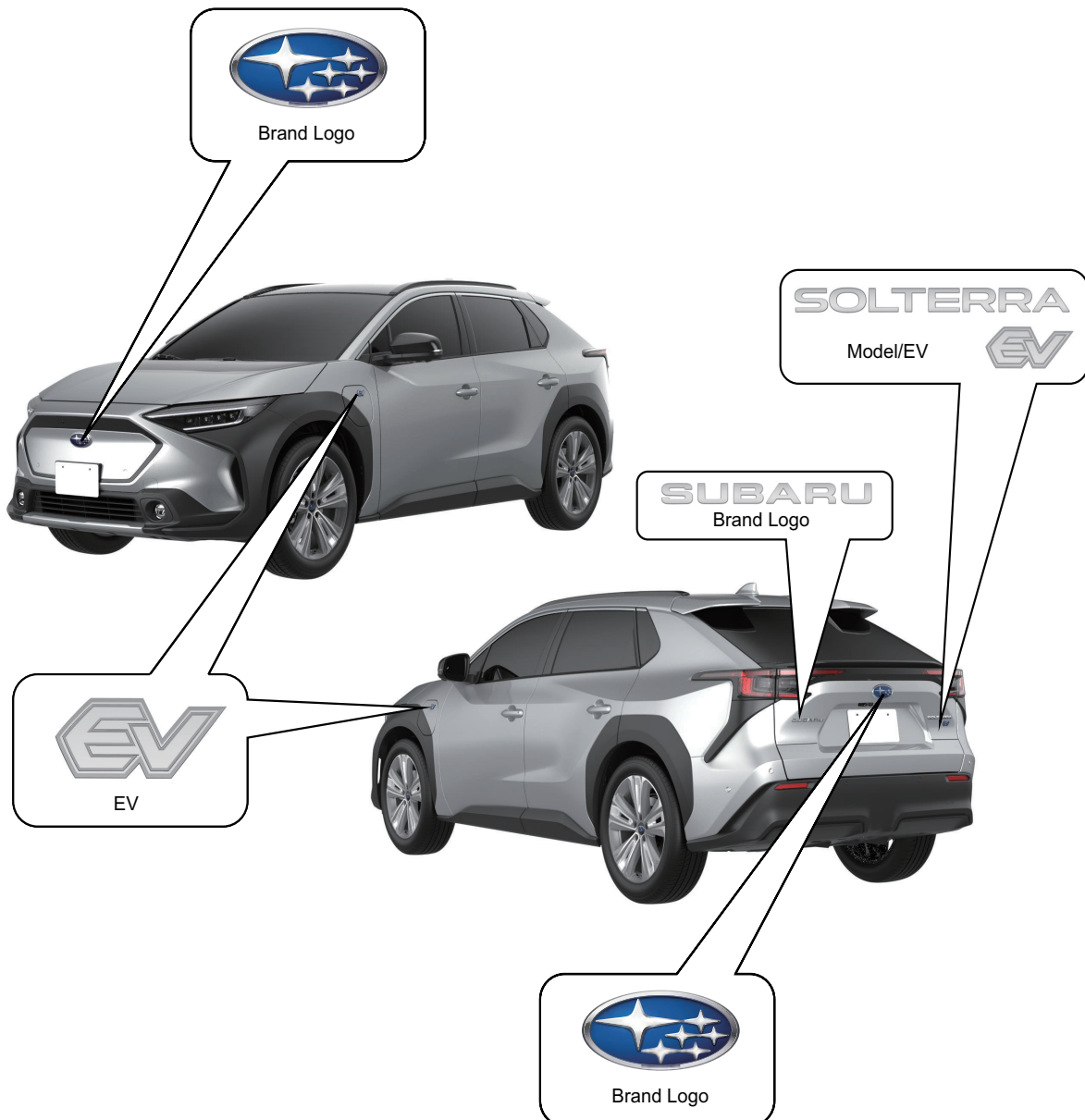

Vehicle Identification

Frame Number

- A frame number is stamped on the name plate attached to the motor compartment and front passenger door pillar.
- Characters before a hyphen (e.g.: ○○○○ for the frame number ○○○○-△△△△) represent the vehicle model.
- When a cover is installed under the driver seat, a frame number is stamped on the frame underneath the cover.

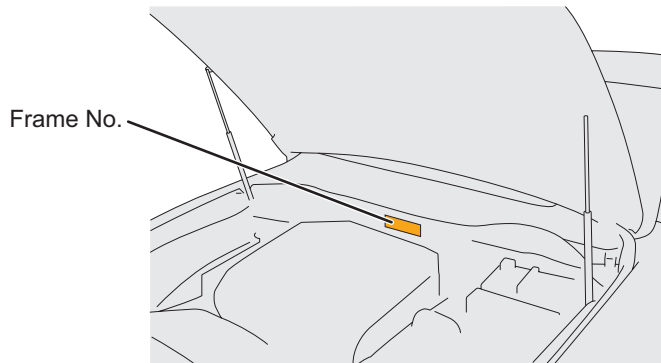
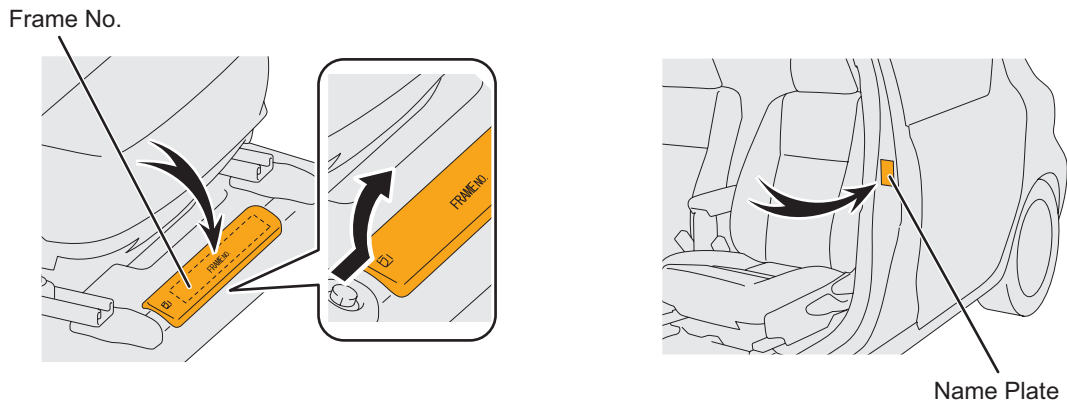

Vehicle Identification Number (VIN)

- The VIN is stamped on the name plate attached to the windshield cowl and driver door pillar.
- The vehicle model can be identified by the VIN.

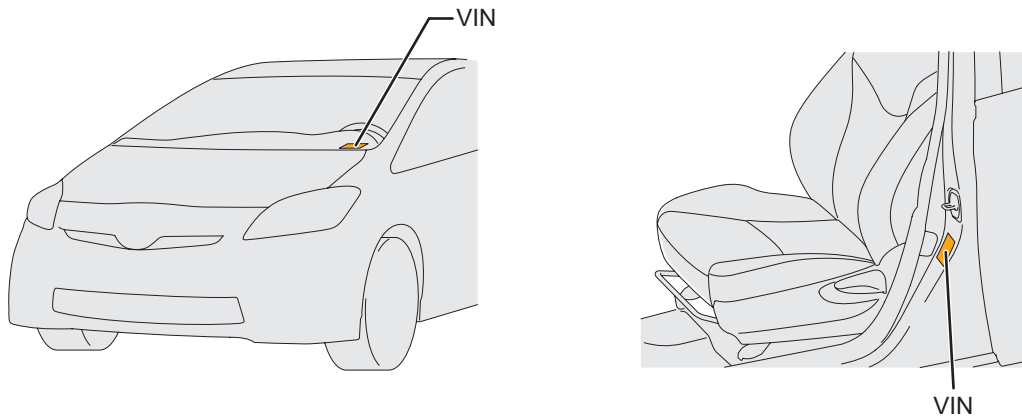

Immobilize Vehicle

- On arrival, completely immobilize the vehicle by following procedures 1, 2 and 3 to ensure safe emergency response operations.

1. Chock wheels and set the parking brake.

- For vehicles with a switch type, operate the switch twice in order to make sure that the vehicle is securely fixed in place.

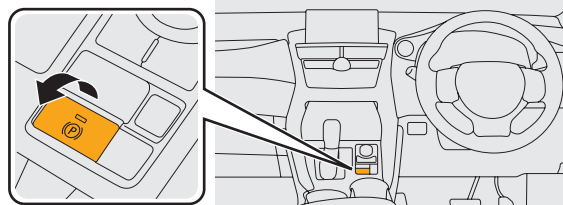

Switch Type (Pull-type Switch)

2. Press the P position switch.

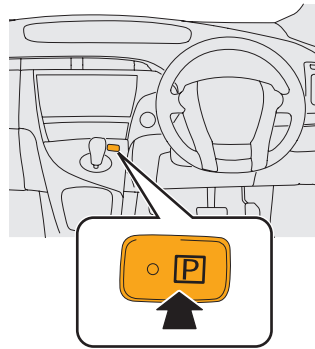

P Position Switch Type

3. To facilitate emergency response operations, lower the windows, open the back door, unlock the doors and take other necessary actions before shutting off the vehicle.

- The following systems are powered by the 12 V battery. Operate them as required before disconnecting the battery.

- Power door lock

Immobilize Vehicle

- Power window
- Power seat

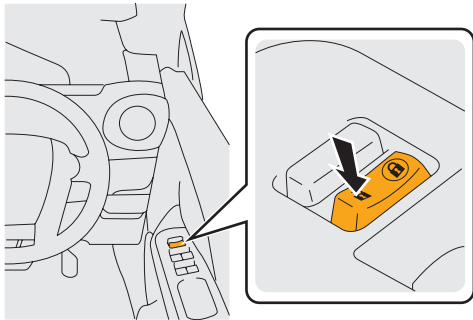

Door Unlock

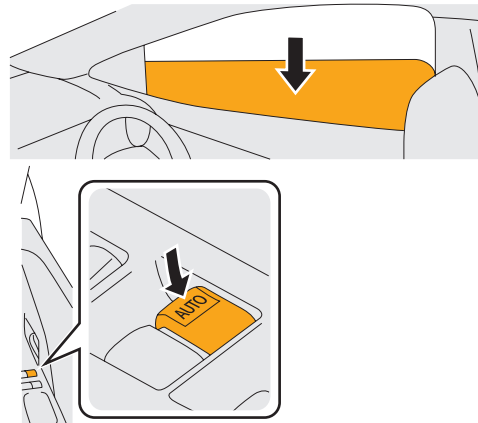

Power Window Adjustment



Seat Adjustment



NOTICE

■ Once the 12 V battery is disconnected (see page 44), power controls will not operate.

Immobilize Vehicle

Vehicle with High Voltage Battery

- Electric vehicles are equipped with a high voltage electrical system (120 to 800 V).



WARNING

- To prevent serious injury or death from severe burns or electric shock, avoid touching, cutting, or breaching any orange high voltage power cable or high voltage component. Wear appropriate protective equipment such as insulated gloves when there is a risk of touching high voltage power cables or high voltage components.

Disable Vehicle

- To ensure safe emergency response operations, the vehicle must be completely turned off by shutting off the power from the fuel pump, SRS airbag, high voltage battery, plug-in charging system, etc.
- Confirm the vehicle status. If **any of the following conditions exist**, the vehicle may not shut off.

- Power switch is in ACC or ON position.
- Meters are illuminated.
- Air conditioning is operating.
- Audio system is operating.
- Wipers are operating.
- Navigation or other displays are turned on.
- Charge cable is connected.



- Failure to shut off and disable the vehicle before emergency response procedures are performed may result in serious injury or death from unintentional deployment of the SRS airbags or unintentional actuation of the seatbelt pretensioners.

- Completely shut off the vehicle by following procedures 1 or 2.

Procedure 1

1. Power switch once to shut off the vehicle.

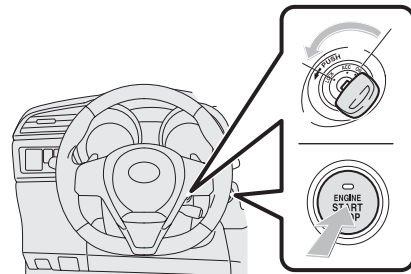

- If the vehicle is equipped with power switch the vehicle is shut off when **ALL of the following conditions are met**. With all of the following conditions met, do not push the power switch as the vehicle will start.
 - Meters are not illuminated.
 - Air conditioning is not operating.
 - Audio system is not operating.
 - Wipers are not operating.
 - Navigation and other displays are turned off.
 - Charge cable is disconnected.

Disable Vehicle



NOTICE

- The power switch operates as follows.

With the brake pedal depressed:

Vehicle Start → Stop → Start ... is repeated every time the switch is pushed.

With the brake pedal released:

Accessory → Ignition-On → Off → Accessory... is repeated.

- When in "Accessory" mode, the radio and other accessory components are operational.
- When in "Ignition-On" mode, the power windows, wipers, heater/air conditioner fan and other components including SRS system are operational.
- The vehicle will not start if the brake pedal is not depressed, even if the switch is pushed.

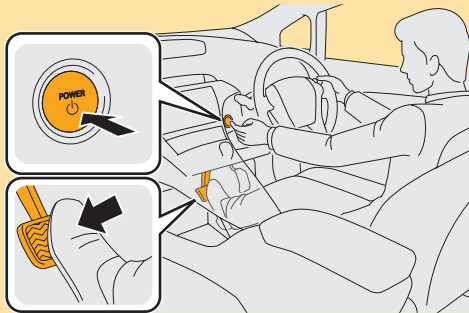

Brake Pedal Depressed

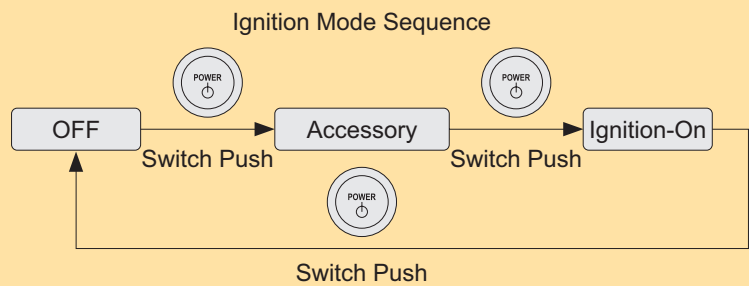

Brake Pedal Released

2. When the vehicle is equipped with an power switch, keep the electrical key transmitter 5 meters (16.4 feet) or more away from the vehicle.



NOTICE

- If the electrical key transmitter is in the cabin or near the vehicle, the vehicle may start depending on what operations are performed. For example, if the power switch is pushed.
- To prevent unexpected starting of the vehicle, place the electrical key transmitter outside of the detection area.

Disable Vehicle

3. Disconnect the negative (-) terminal of the 12 V battery.

- The 12 V battery is installed in the motor compartment.
- Refer to the Quick Reference Sheet (QRS) for each model for the location of the 12 V battery.

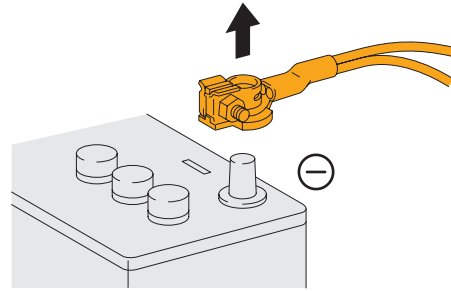

- Shut off the power to the electrical system to prevent electrical fires and to keep the vehicle from starting.
- After the negative (-) terminal of the 12 V battery has been disconnected and the power has been shut off, approximately 12 V is maintained between the positive (+) terminal and negative (-) terminal of the sub-battery for up to approximately 10 minutes.

Procedure 2 (Alternate if the power switch is inoperative)

1. Open the hood.

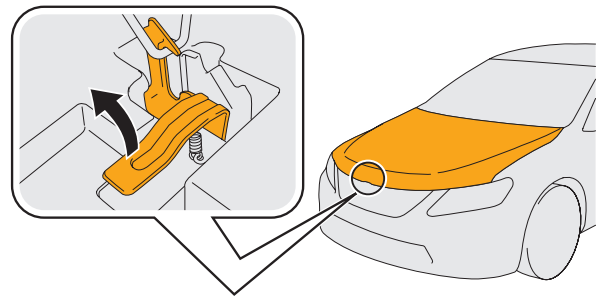

2. Remove the motor compartment fuse box cover.

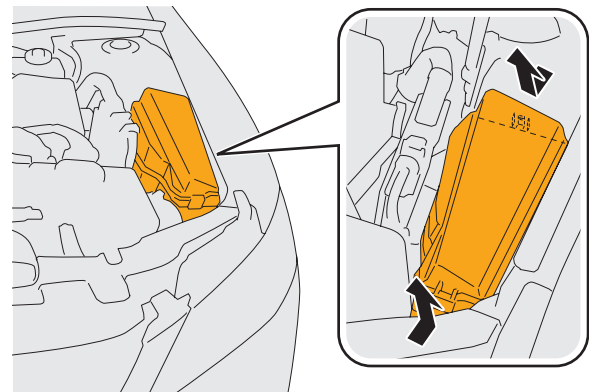

Disable Vehicle

3. Remove the appropriate fuse.

- Refer to the Quick Reference Sheet (QRS) for each model for the fuse to be removed.

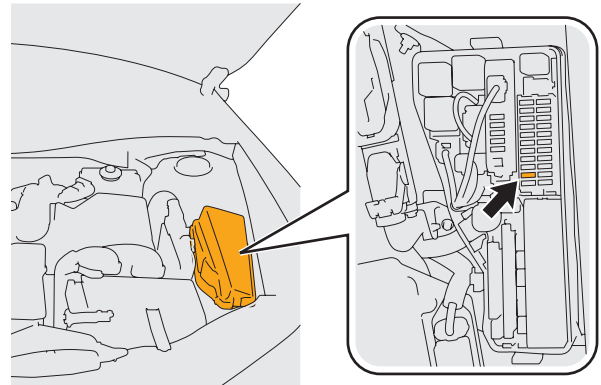

NOTICE

- If the correct fuse cannot be identified, pull **ALL** fuses in the fuse box **until all of the following conditions are met.**

- Meters are turned off.
- Air conditioning is turned off.
- Audio system is turned off.
- Wipers are turned off.
- Navigation and other displays are turned off.

4. Disconnect the negative (-) terminal of the 12 V battery.

- The 12 V battery is installed in the motor compartment.
- Refer to the Quick Reference Sheet (QRS) for each model for the location of the 12 V battery.

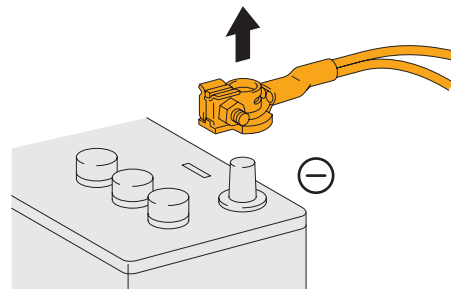

NOTICE

- Shut off the electrical system to prevent electrical fires and to keep the vehicle from starting.

Vehicle with High Voltage Battery

- Electric vehicles are equipped with a high voltage electrical system (120 to 800 V).



WARNING

- The high voltage system may remain charged for up to 10 minutes after the vehicle is shut off and disabled (see page 44). Failure to shut off and disable the vehicle before emergency response procedures are performed may result in serious injury or death from severe burns and electric shock from the high voltage electrical system.
- To prevent serious injury or death from severe burns or electric shock, avoid touching, cutting, or breaching any orange high voltage power cable or high voltage component. Wear appropriate protective equipment such as insulated gloves when there is a risk of touching high voltage power cables or high voltage components.
- NEVER assume the electric vehicle is shut off simply because it is silent. Always observe the instrument cluster for the **READY** indicator status to verify whether the high voltage system is on or shut off. The high voltage system is shut off when the **READY** indicator is off.

Vehicle with Plug-in Charge System

- Electric vehicles are equipped with a system to charge the high voltage battery using power from an external power source.
- If a charge cable is connected to the charging inlet of the vehicle, disconnect the charge cable as follows to stop charging.

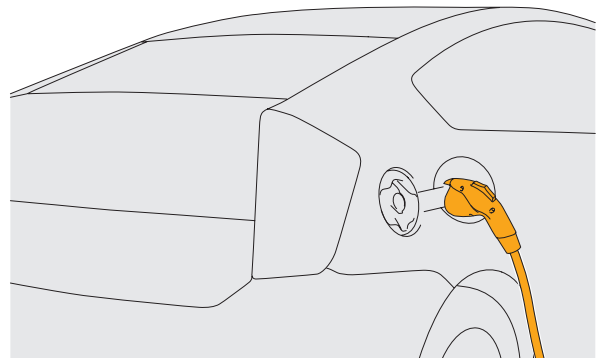

Disable Vehicle

1. Push the latch release button on the top of the charging connector and pull it away from the charging inlet of the vehicle.

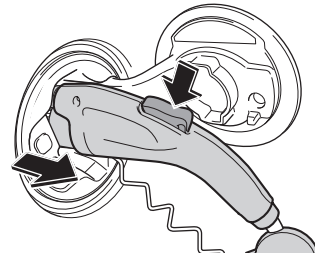

NOTICE

- If the lock of the charge cable assembly connector cannot be released, turn OFF or unplug the external charger, or turn its main breaker OFF.
- The lock of the charge cable assembly connector cannot be released during fast charging. If charging does not stop even when the charger is turned OFF, turn its main breaker OFF.

2. Close the charging inlet cap and charging port lid.

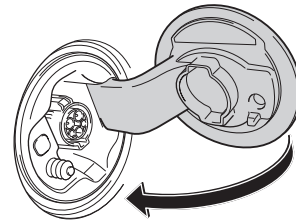

3. Turn off the external charger by unplugging it or turning its main circuit breaker off.

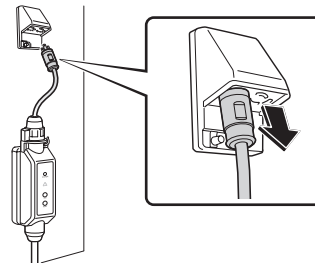

WARNING

- To prevent serious injury or death from severe burns or electric shock, shut off the utility circuit supplying power to the charge cable before disconnecting it if the vehicle, charge cable or external charger is submerged in water.

Stabilize Vehicle

- Crib at four points directly under the front and rear pillars using wooden blocks or equivalent objects.

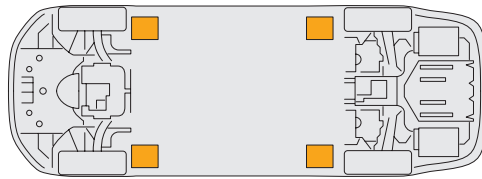
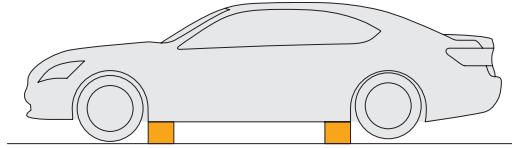

WARNING

- Do not place cribbing such as wooden blocks or rescue air lifting bags under the high voltage power cables. Failure to do so may cause heat generation, bursting of the air lifting bags, damage to the high voltage power cables resulting in a vehicle fire, crushing accident, electrical shock, possibly leading to serious injury or death.

Access Patients

- Make sure that the vehicle is immobilized and disabled (see page 44), then open or remove windows and doors to access patients.
- Secure the necessary space for performing operations by adjusting the position of the steering wheel and seats and removing the head rests.
- Refer to “Components Requiring Special Attention” for details of adjustment and removal of components.



WARNING

- The SRS airbags and seatbelt pretensioners may remain powered for up to 90 seconds after the vehicle is shut off and disabled (see page 44). Wait at least 90 seconds before starting any operation. Failure to shut off and disable the vehicle before emergency response procedures are performed may result in serious injury or death from unintentional deployment of the SRS airbags or unintentional actuation of the seatbelt pretensioners, pop up hood or active headrests.
- Depending on the circumstances surrounding a collision, such as vehicle speed, point of impact, occupant detection etc., the SRS airbags, seatbelt pretensioners, will not always be activated and may remain active. If an unactivated inflator of these systems is cut, the powder inside the inflator may ignite resulting in airbag deployment. To prevent serious injury or death from unintentional SRS airbag deployment or unintentional actuation of the seatbelt pretensioners, pop up hood or active headrests, avoid breaching the inflators.
- Immediately after an SRS airbag is deployed or a seatbelt pretensioner, is actuated, the components are extremely hot and may cause burns if touched.
- If an SRS airbag deploys with all doors and windows closed, inflation gas may cause breathing difficulty.
- If residue that is produced during the operation of SRS airbags, seatbelt pretensioners comes in contact with skin, rinse it off immediately to prevent skin irritation.

Vehicle with High Voltage Battery

- Electric vehicles are equipped with a high voltage electrical system (120 to 800 V).



WARNING

- The high voltage system may remain charged for up to 10 minutes after the vehicle is shut off and disabled (see page 44). Failure to shut off and disable the vehicle before emergency response procedures are performed may result in serious injury or death from severe burns and electric shock from the high voltage electrical system.
- To prevent serious injury or death from severe burns or electric shock, avoid touching, cutting, or breaching any orange high voltage power cable or high voltage component. Wear appropriate protective equipment such as insulated gloves when there is a risk of touching high voltage power cables or high voltage components.

Cut Vehicle

- Pay special attention to the location of structural reinforcements, SRS and high voltage electrical system components when cutting a vehicle.
- Refer to the Quick Reference Sheet (QRS) for each model for model specific information such as component locations, etc.

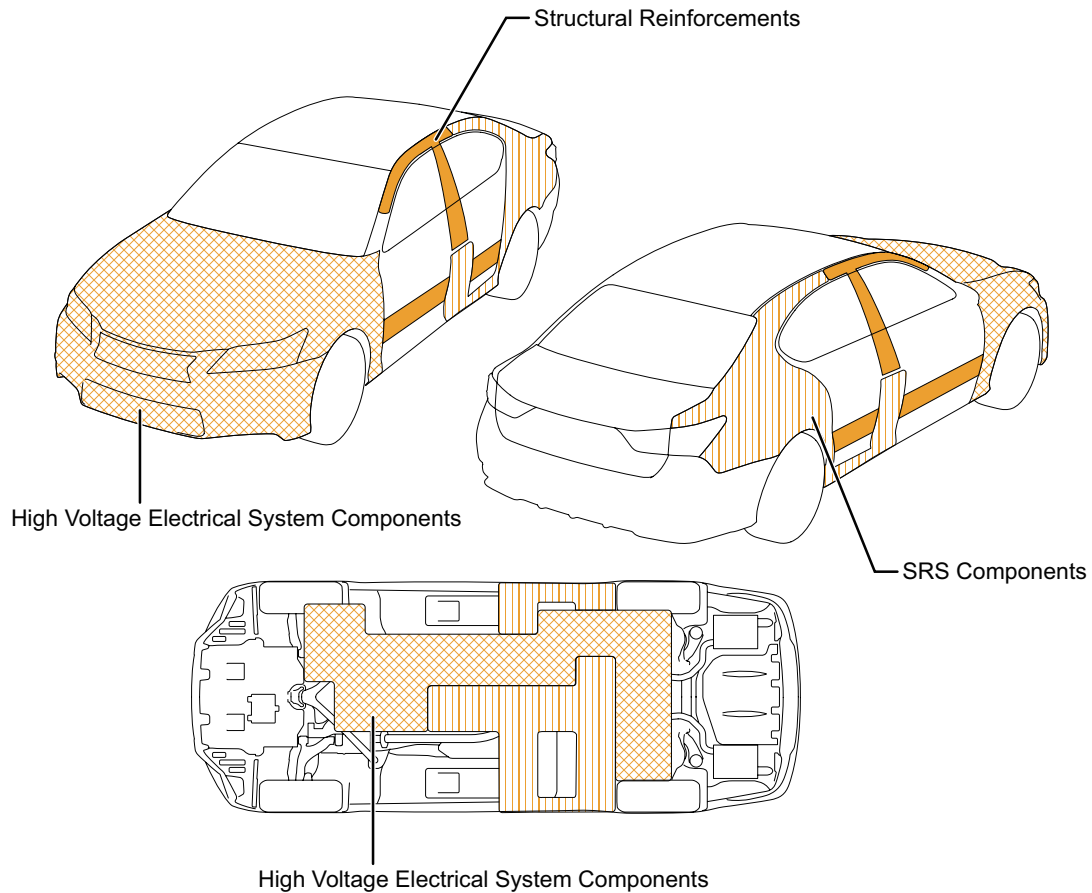

WARNING

- To prevent serious injury from a fire caused by sparks, use a hydraulic cutter or other tools that do not generate sparks when cutting the vehicle.



NOTE

- If the SRS airbag, seatbelt pretensioner, has already been activated, the inflator can be cut.

Fire

- During the initial attack on a fire, extinguish the fire with copious amounts of water. This will also cool down the vehicle.



- Plastic and other components will generate toxic gases when they melt. Wear appropriate protective equipment such as a protective mask when extinguishing a fire.

Fire Extinguisher

- Water has been proven to be a suitable extinguishing agent.
- Also use a fire extinguisher suitable for electrical fires (burning of electrical wiring, electric devices, etc.) as well as general fires (burning of solid objects, etc.).

Vehicle with High Voltage Battery

- Electric vehicles are equipped with a high voltage battery.
- Extinguish the fire with copious amounts of water to cool down the high voltage battery.
- Refer to the Quick Reference Sheet (QRS) for each model for the high voltage battery location.



- To avoid serious injury or death from severe burns or electric shock, never breach or remove the high voltage battery assembly cover under any circumstances, including fire.
- If only a small amount of water is used to extinguish a fire, a short circuit may occur in the high voltage battery, causing the fire to reignite.



- It is recommended to allow the high voltage battery to burn itself out if it is judged that it is difficult to apply copious amounts of water to the high voltage battery.

Vehicle with Lithium ion (Li-ion) Battery



- Burning Li-ion batteries may irritate the eyes, nose or throat. In case of contact with the vapor from the electrolyte, it may irritate the nose or throat. To avoid injury by coming in contact with the electrolyte or vapor, wear appropriate protective equipment such as rubber gloves, safety goggles, protective mask or SCBA when there is a risk of touching electrolyte.

Submersion

- Pull the vehicle out of water as much as possible. Immobilize the vehicle (see page 41) and disable the vehicle (see page 44) before starting any operation.



NOTICE

- A short circuit due to electrical corrosion (wiring and circuit boards become corroded due to an electrochemical reaction with water) may cause a vehicle fire after some time has elapsed.
- To prevent a vehicle fire, avoid turning the power switch of a submerged vehicle to ACC or ON.

Vehicle with High Voltage Battery

- Electric vehicle does not have high voltage potential on the metal vehicle body, and is safe to touch.
- It is safe to enter the water as the vehicle and water have the same electrical potential.



WARNING

- Touching exposed orange high voltage power cables or high voltage components such as the high voltage battery may cause electrical shock due to a change in electrical potential.
- To prevent serious injury or death from severe burns or electric shock, avoid touching, cutting, or breaching any orange high voltage power cable or high voltage component. Wear appropriate protective equipment such as insulated gloves when there is a risk of touching high voltage power cables or a high voltage components.

Spills

- Vehicles contain various fluids such as coolant, transmission oil, brake fluid, power steering fluid, window washer fluid and 12 V battery electrolyte.

Coolant

- Long Life Coolant (LLC) that is used to cool the inverter contains ethylene glycol for freezing temperature control and anticorrosion additives for preventing metal components from corroding.

Traction Battery Coolant

- As coolant is used as the cooling method for the high voltage battery, a coolant leak in the high voltage section during an accident, malfunction, etc., could result in a short circuit or similar possibly leading to battery overheating and the emission of fumes. For this reason, a coolant which resists the flow of electricity is used for the cooling system of the traction battery.
- As the coolant is different to traditional engine coolant, an orange color is used in order to be the same as high voltage systems.

Lubrication Oil

- Transmission oil and gear oil are used for lubrication and contain mineral oils and synthetic oils.

Brake Fluid

- Brake fluid contains several types of glycol-ether and anticorrosion additives for preventing metal components from corroding.



NOTICE

- Brake fluid contains ingredients that damage painted surfaces. If any comes in contact with the vehicle body, the paint may come off.

Power Steering Fluid

- Power steering fluid contain mineral oils and synthetic oils.

Window Washer Fluid

- Window washer fluid contains alcohol for freezing temperature control.

12 V Battery Electrolyte

- 12 V battery electrolyte contains dilute sulfuric acid.

Spills



WARNING

- Dilute sulfuric acid may cause irritation of the skin if contacted. Wear appropriate protective equipment such as rubber gloves and safety goggles when there is a risk of touching electrolyte.



NOTICE

- 12 V battery electrolyte contains ingredients that damage painted surfaces. If any comes in contact with the vehicle body, discoloration or other damage may occur.

Vehicle with High Voltage Battery

- There is 1 type of high voltage battery; the lithium ion type.

Lithium ion (Li-ion) battery

- The Li-ion battery electrolyte, mainly consisted of carbonate ester, is a flammable organic electrolyte. The electrolyte is absorbed into the electrodes and the separators. It may leak in case of damages to the high voltage battery, but it would not be a large amount.
- Electrolyte will quickly evaporate if leaked from the battery cell.



WARNING

- The flammable organic electrolyte which primarily contains carbonate ester is harmful to the human body. In case of contact with the electrolyte, it may irritate the eyes, nose, throat and skin. In case of contact with the smoke or vapor from leaked electrolyte or a burning battery, it may irritate the eyes, nose or throat. To avoid injury caused by coming in contact with the electrolyte or the vapor, wear appropriate protective equipment such as rubber gloves, safety goggles, protective mask or SCBA when there is a risk of touching electrolyte.
- If the electrolyte is spilled, keep it away from fire and ensure the area is well ventilated. Absorb the electrolyte with a piece of cloth or equivalent absorbent material, and keep it in an airtight container for proper disposal.

Gas Leaks

- There are various types of gas used in vehicles. For example, there is nitrogen (N₂) gas used in gas filled dampers and refrigerant gas for air conditioners.

Nitrogen (N₂) Gas

- Nitrogen (N₂) is used in gas filled dampers.
- The gas is colorless, odorless, and harmless.

Refrigerant Gas

- The refrigerant gas used in air conditioner is R-134a or R-1234yf.
- The gas is containing carbon and fluorine.
- The gas is colorless, odorless, and harmless.

Damaged Vehicle Handling Key Points

■ Points to be noted when handling damaged vehicles are provided in this section.

Towing Damaged Vehicle

- Loading a vehicle onto a car carrier (flat bed trailer) is the preferred method of towing.
- Only the FWD (Front Wheel Drive) vehicles are available to tow with rear wheels on the ground.
- If towing the vehicle with all four wheels on the ground is unavoidable, only tow it for a short distance (such as to a car carrier (flat bed trailer)) in a forward direction at a low speed (below 30 km/h (18 mph)).
- Refer to the illustrations on the following page for correct and incorrect methods of towing AWD (All Wheel Drive) vehicles.



- When towing a vehicle with all four wheels on the ground, make sure the vehicle is in “Ignition-On” mode. If in “Off” mode, the steering wheel may lock, making the steering inoperative.



- Exceeding the towing distance or speed limit when towing a vehicle with all four wheels on the ground or towing a vehicle with the vehicle facing backwards, may damage the transmission or transaxle.

Parking Lock



- The parking lock for vehicles equipped electric shift switches (vehicles with a P position switch) cannot be released while the 12 V negative (-) battery terminal is disconnected. When moving the vehicle, use a jack, etc.

Steering Wheel Lock

- The steering wheel can be unlocked by pushing the power switch until in "Ignition-On" mode.
- When it is difficult to release the lock, turn the steering wheel in either direction while pushing the power switch or turning the key.

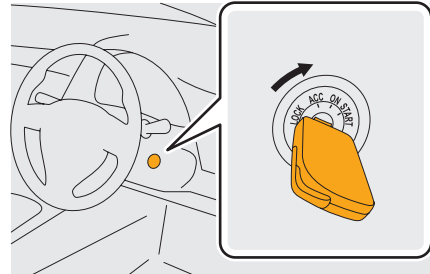

- When a vehicle is equipped with the electrical key transmitter system, the steering wheel cannot be unlocked if the negative (-) terminal of the 12 V battery is disconnected. Use wheel dollies or similar equipment when moving the vehicle.

Precautions for FWD (Front Wheel Drive) vehicle

- Tow the vehicle with the front wheels or all four wheels off the ground.

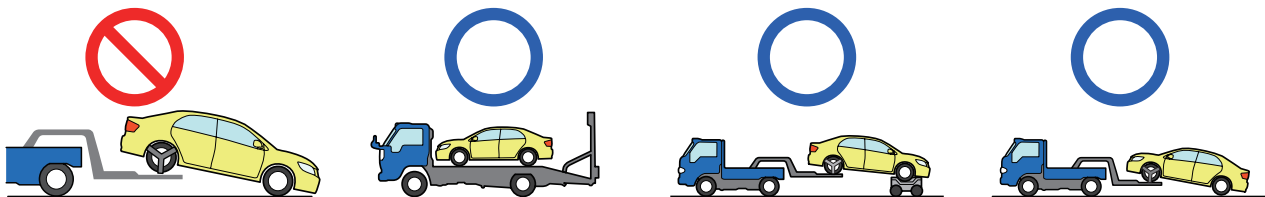

Precautions for AWD (All Wheel Drive) vehicles

- Tow the vehicle with all four wheels off the ground.

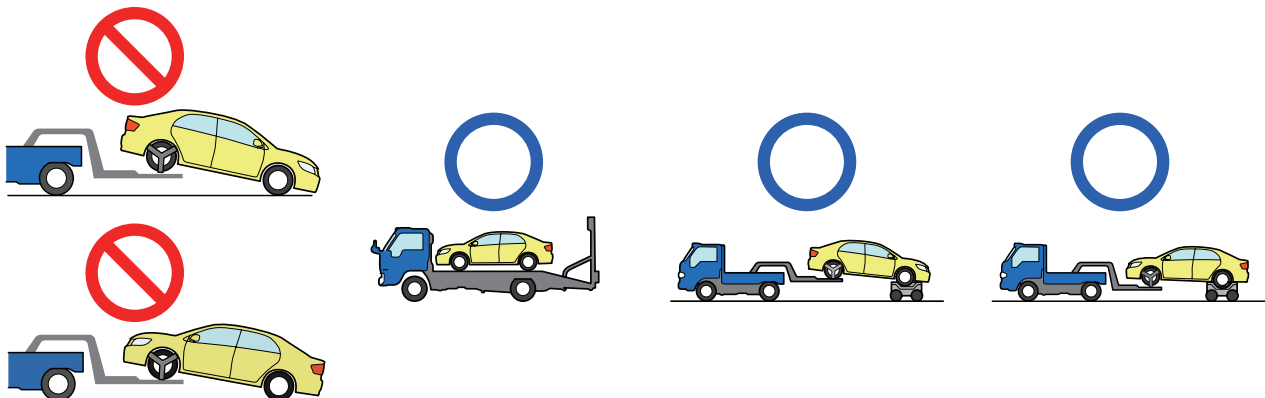

Vehicle with High Voltage Battery

- Make sure the negative (-) terminal of the 12 V battery is disconnected, then load the vehicle onto a car carrier (flat bed trailer).
- If towing the vehicle with all four wheels on the ground is unavoidable, only tow it for a short distance (such as to a car carrier (flat bed trailer)) in a forward direction at a low speed (below 30 km/h (18 mph)).
- Refer to the above illustrations for correct and incorrect methods of towing FWD and AWD vehicles.



WARNING

- Electric vehicles are equipped with a high voltage electrical system (120 to 800 V).
- To prevent serious injury or death from severe burns or electric shock, avoid touching, cutting, or breaching any orange high voltage power cable or high voltage component. Wear appropriate protective equipment such as insulated gloves when there is a risk of touching high voltage power cables or high voltage components.



NOTICE

- If electric vehicles are towed with the drive wheels on the ground, it could have adverse effects on the high voltage system and damage it.

Storing a Damaged Vehicle

- Drain oil and other fluids, then disconnect the negative (-) terminal of the 12 V battery before storing a damaged vehicle.

Submerged Vehicle

- In addition to the normal procedures, remove the water from the vehicle.



NOTICE

- A vehicle that has been submerged in water poses a threat of vehicle fire after some time for possible short circuits due to electrical corrosion (wiring and circuit boards to corrode in an electrochemical reaction with water). To store a vehicle that has been submerged in water, choose a well-ventilated place at least 15 meters (49.2 feet) away from other objects.
- To prevent a vehicle fire, avoid turning the ignition switch or power switch of a submerged vehicle to ACC or ON.

Vehicle with High Voltage Battery

- In addition to the normal procedures, remove the service plug from the high voltage battery before storing a damaged vehicle.



WARNING

- The service plug is a high voltage component. Touching it without appropriate protective equipment may result in serious injury or death from severe burns and electric shock from the high voltage electrical system. Wear appropriate protective equipment such as insulated gloves when touching the service plug.
- The high voltage battery is still charged with high voltage electricity even after the vehicle is shut off, disabled (see page 44) and the service plug is removed from the high voltage battery.
- To prevent serious injury or death from severe burns or electric shock, avoid touching, cutting, or breaching any orange high voltage power cable or high voltage component. Wear appropriate protective equipment such as insulated gloves when there is a risk of touching high voltage power cables or high voltage components.
- When the person(s) in charge of handling the damaged vehicle is away from the vehicle, other person(s) may accidentally touch the vehicle and be electrocuted, resulting in severe injury or death. To avoid this danger, display a "HIGH VOLTAGE DO NOT TOUCH" sign to warn others (print and use page 17 of this guide).



NOTICE

- A high voltage battery may cause a vehicle fire after some time for possible short circuits inside due to the impact of collision or electrical corrosion. To store a vehicle equipped with a high voltage battery, choose a well-ventilated place at least 15 meters (49.2 feet) away from other objects.

