

EMERGENCY RESPONSE GUIDE

MACK LRBE

PRODUCTION START : 2021



Contents

0. Rescue sheet	Page 1
1. Identification/recognition	Page 3
2. Immobilisation/stabilization/lifting	Page 3
3. Disable direct hazards/safety regulations	Page 4
4. Access to the occupants	Page 6
5. Stored energy/liquid/gases/solid	Page 7
6. In case of fire	Page 8
7. In case of water submersion	Page 8
8. Towing/transportation/storage	Page 9
9. Important additional information	Page 10
10. Explanation of pictograms used	Page 10



MACK

LRBE

PRODUCTION START : 2021

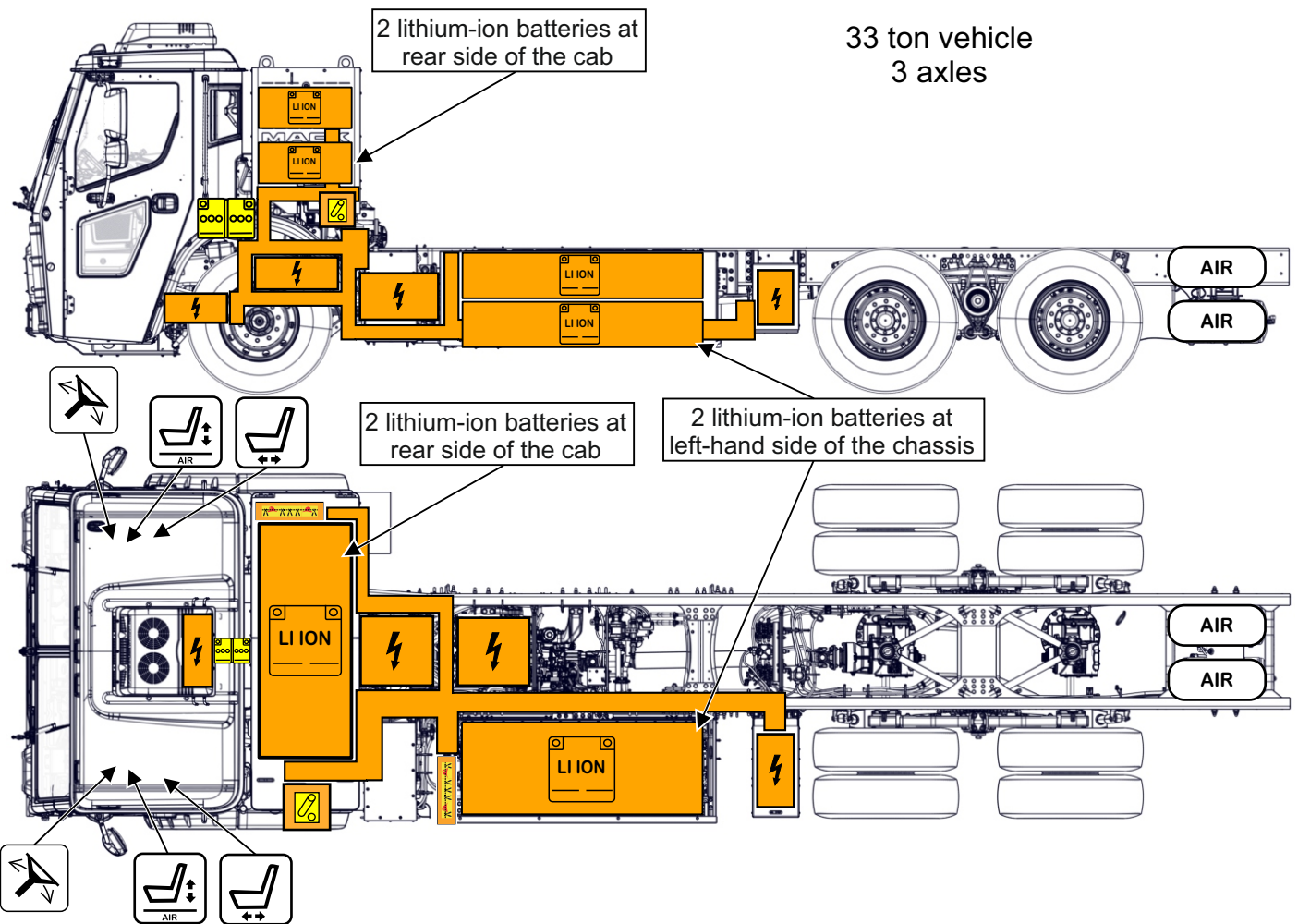
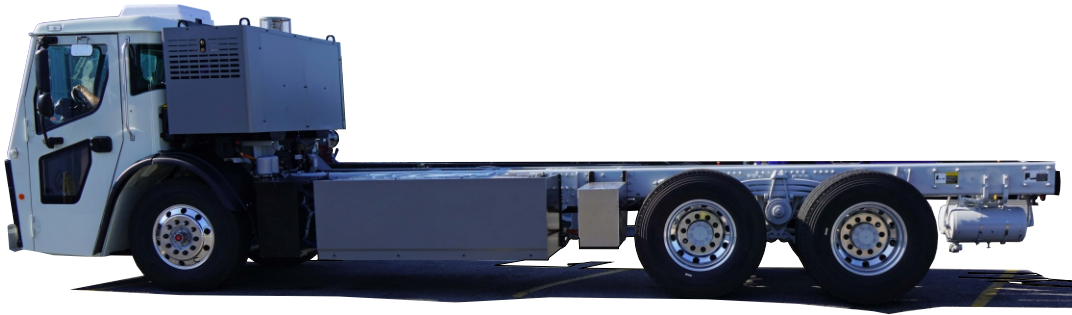

High voltage lithium-ion battery	Low voltage device that disconnects the high voltage	Low voltage battery	Air tank	Seat height adjustment	Cable cut
Steering wheel tilt control	High voltage component	High voltage cable	Seat longitudinal adjustment	Ignition key	

	Identification number	Version number	Page number
	800077265	06/2021	1



MACK LRBE

PRODUCTION START : 2021

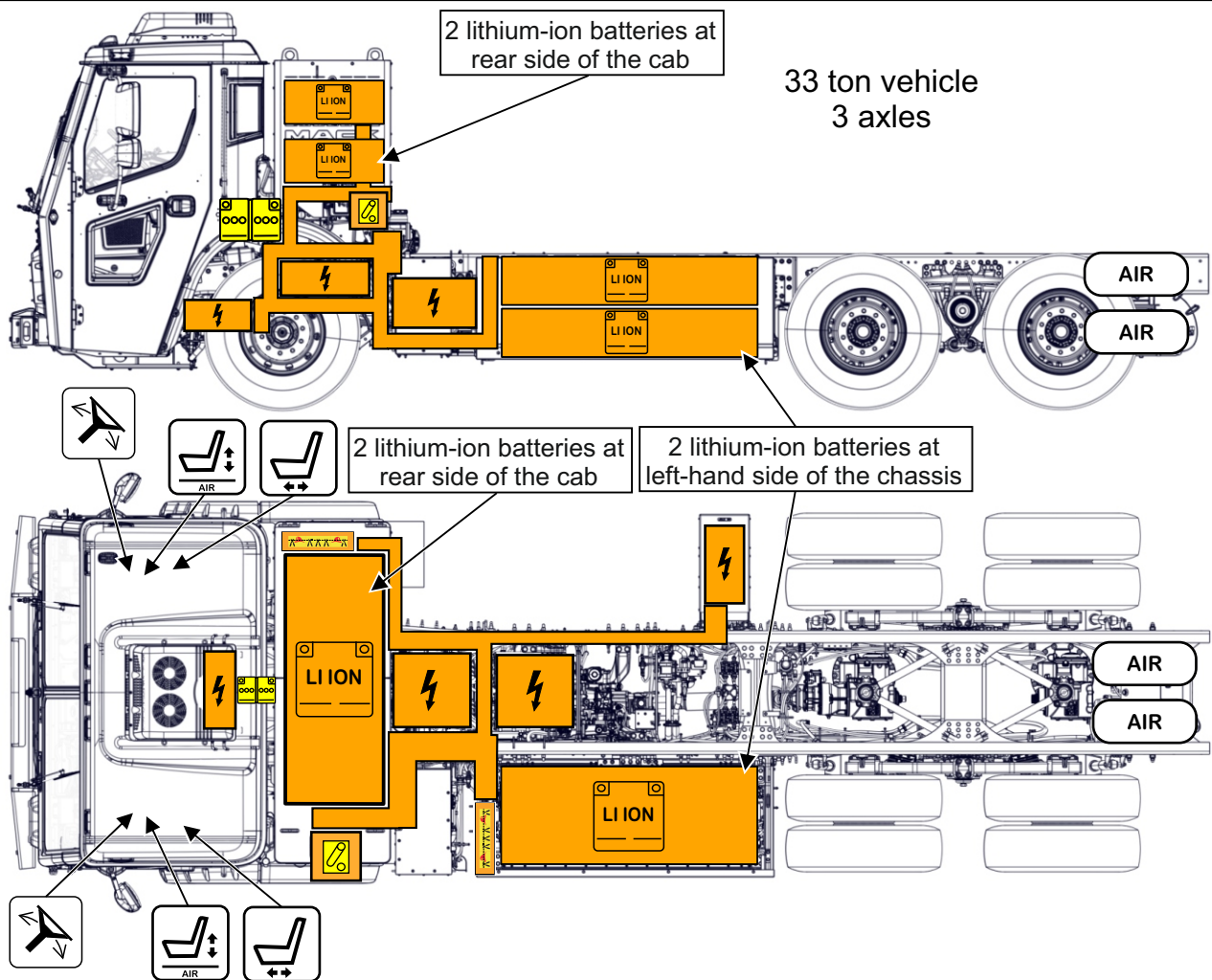
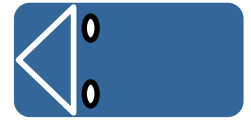

High voltage lithium-ion battery	Low voltage device that disconnects the high voltage	Low voltage battery	Air tank	Seat height adjustment	Cable cut
Steering wheel tilt control	High voltage component	High voltage cable	Seat longitudinal adjustment	Ignition key	

	Identification number	Version number	Page number
	800077265	06/2021	2

1. Identification/recognition

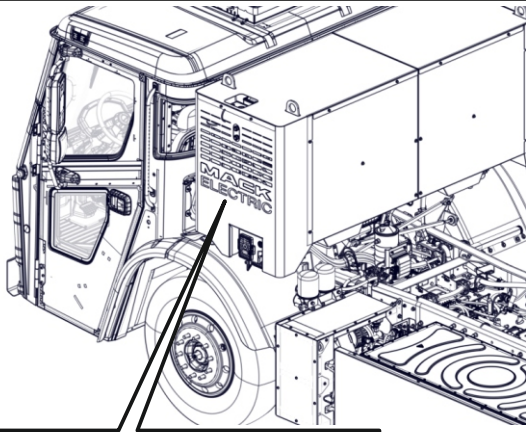

ELECTRIC

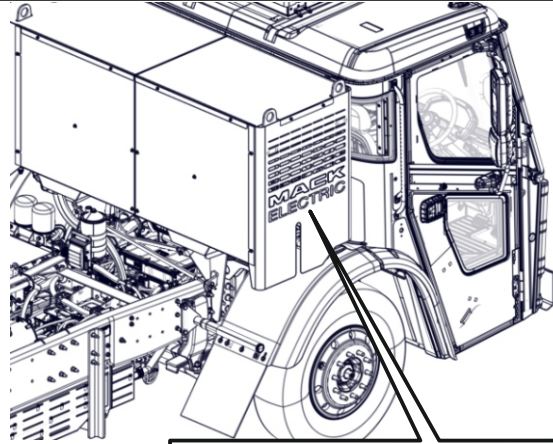

ELECTRIC

➤ Vehicle Identification Number (VIN)

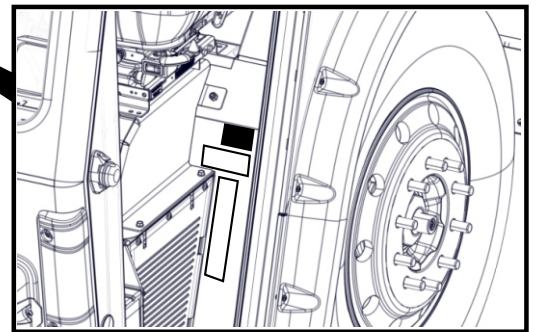
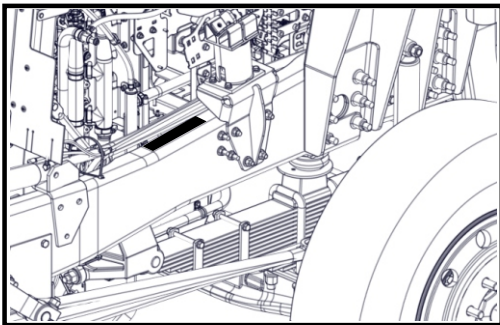
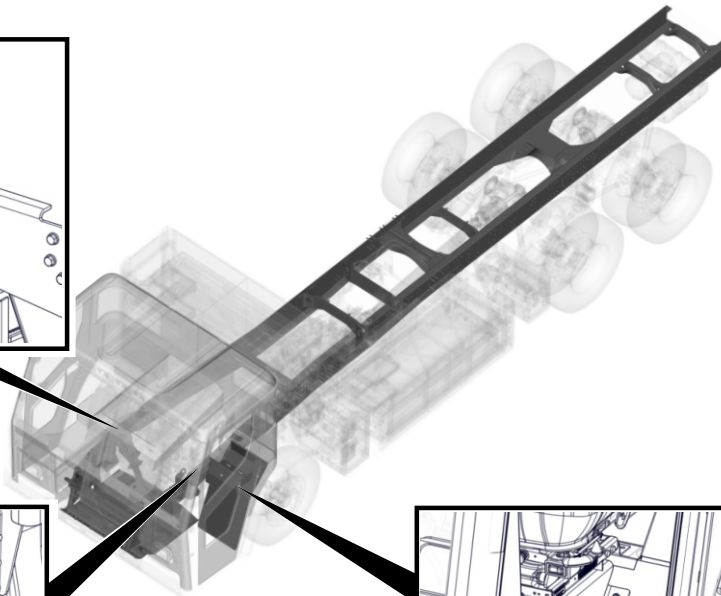
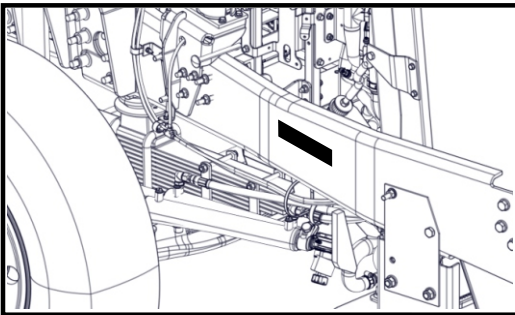

2. Immobilisation/stabilization/lifting



Always approach the truck from the sides to stay out of the potential travel path. Due to lack of noise it can be difficult to determine if the truck is running.

1 Chock the wheels.

2 Apply the parking brake.

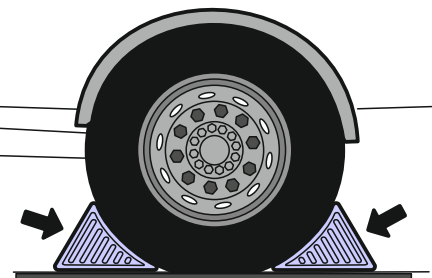

Identification number

800077265

Version number

06/2021

Page number

3

3. Disable direct hazards/safety regulations

➔ Primary procedure

- 1 Check the instrument cluster for any of the symbols (1) and (2) appearing with a beep sound. If yes, a thermal runaway is detected in the lithium-ion batteries.



- 2 Turn off the ignition and remove the key.



- 3 Turn off the chassis switch (up) to initiate the high voltage disconnection process.

Note

All the components are designed to discharge their own capacitance within five seconds.

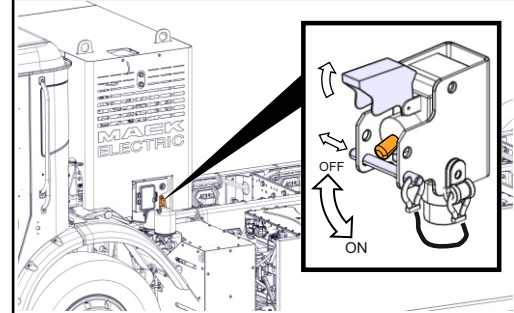
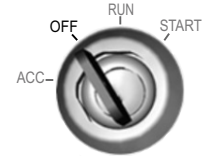

➔ If unable to perform the primary procedure

- 1 Locate the communication cable harness (low voltage) (1) connected to any of the traction batteries.

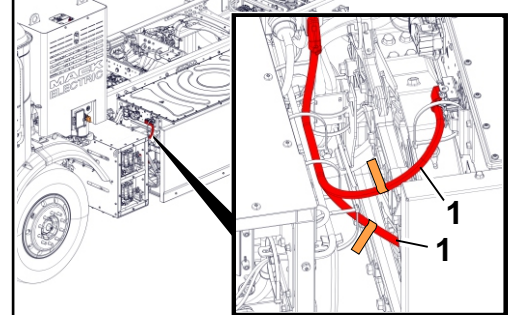

- 2 Cut the communication cable harness on each side of the label to disconnect the traction voltage supply from the traction batteries.

Note

Cutting at any of the locations shown will disable the traction voltage supply.

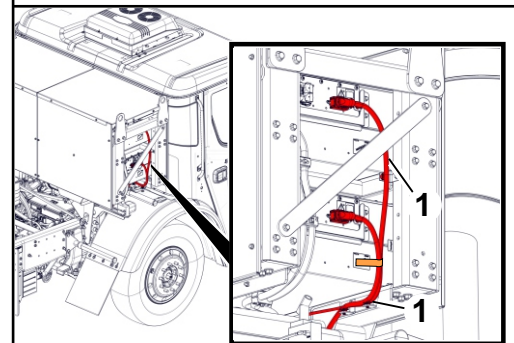

➔ If the truck is charging

- 1 Unlock the cab.
- 2 Press the stop button (1) and wait for the steady yellow light (2) on the charging inlet.
- 3 Remove the charging plug from the charging inlet when the yellow light (2) turns off.

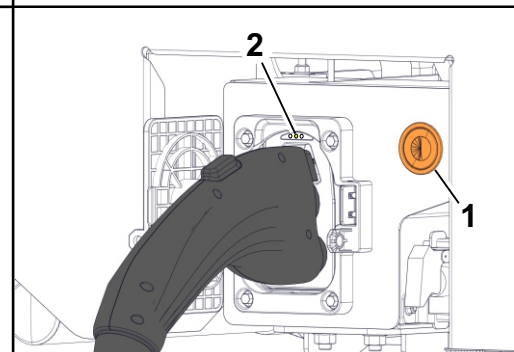

Identification number

80007265

Version number

06/2021

Page number

4

➔ If the charging plug cannot be pulled out : retract the pin manually



1 Turn off the chassis switch (up) to initiate the high voltage disconnection process.

2 Rotate the lever (1) and remove the charging plug (2).

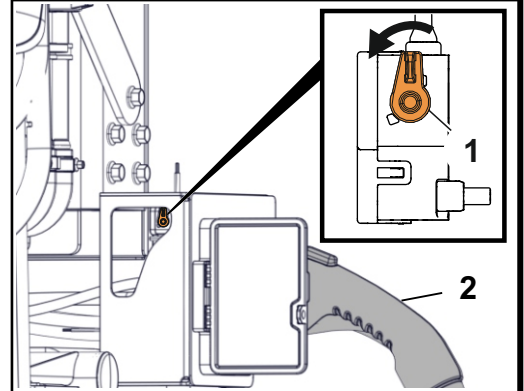
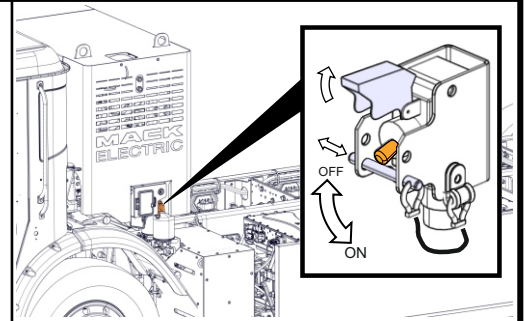

4. Access to the occupants

➔ Opening doors from the outside

1 Insert the key (1) in door lock and turn in anticlockwise direction to unlock the right-hand side door.

2 Turn the key (1) in clockwise direction to unlock the left-hand side door.

3 To open the door, grasp the handle (2) and pull out while exerting some force on the door.

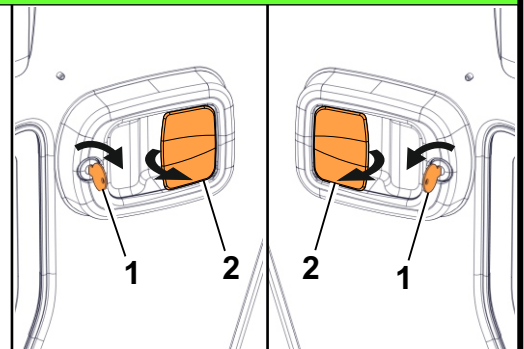

➔ Opening doors from the inside

1 To open the door, pull the handle (1) while exerting some force on the door.

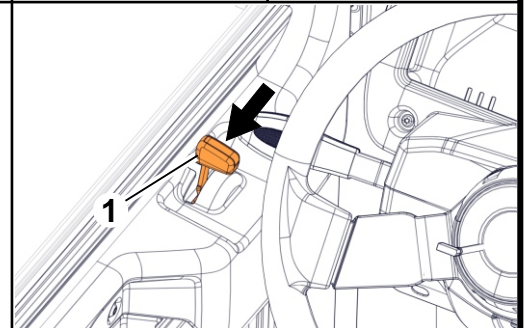

➔ Seat adjustment



1 To raise the seat, pull the air valve button (1) upwards.

2 To lower the seat, push the air valve button (1) downwards.

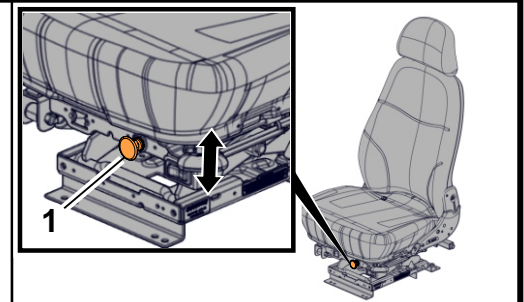

3 Pull the fore and aft adjustment lever (2) and slide the seat to the desired position.

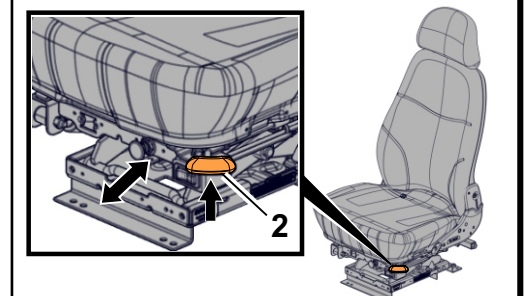

➔ Steering column adjustment

- 1 Pull the telescopic steering adjust lever (1) to adjust the telescopic length of the column.

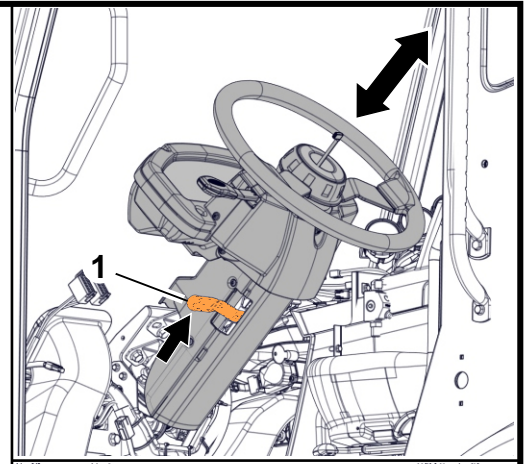

- 2 Pull the telescopic steering adjust lever (1) to adjust the telescopic length of the column.

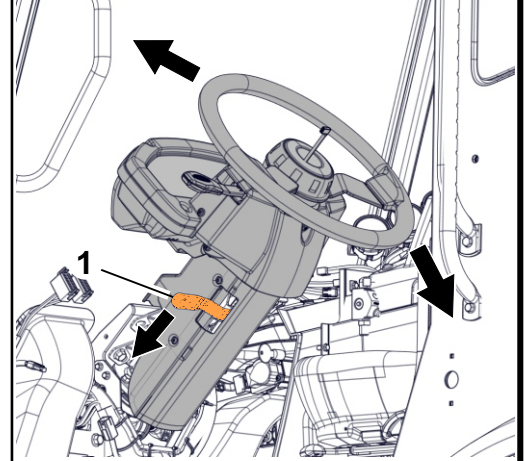

➔ Windows and wind screen

Note

The wind screen and rear glasses are made of laminated glass (1).
Window glasses are made of tempered glass (2).

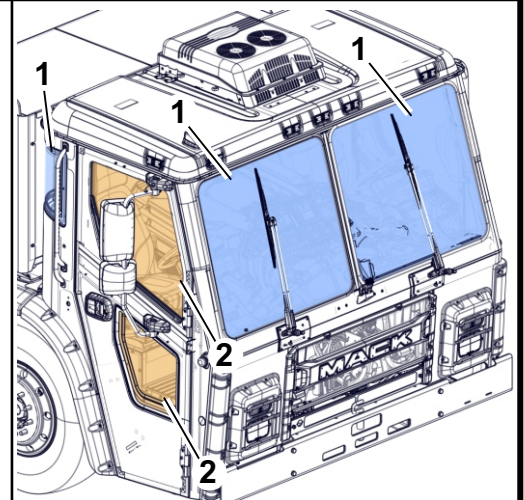







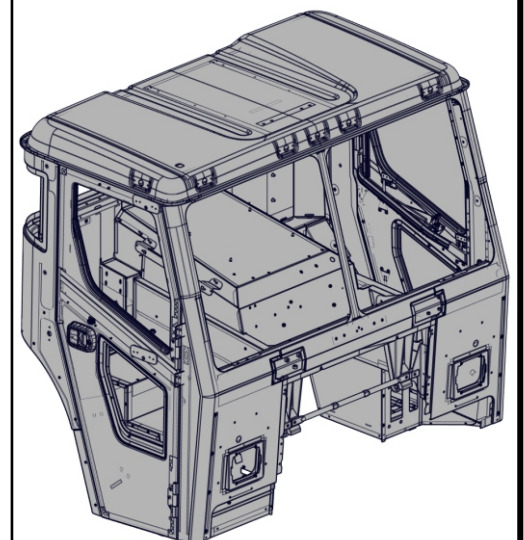

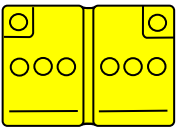

➔ High strength zone

Note

There are no High-Strength and Ultra-High-Strength Steel in the cab.
The cab structure is made predominantly of plain carbon sheet steel that does not exceed 270 Mpa.



5. Stored energy/liquid/gases/solid

	  	12 V
	     	600 V

➔ High-voltage component location

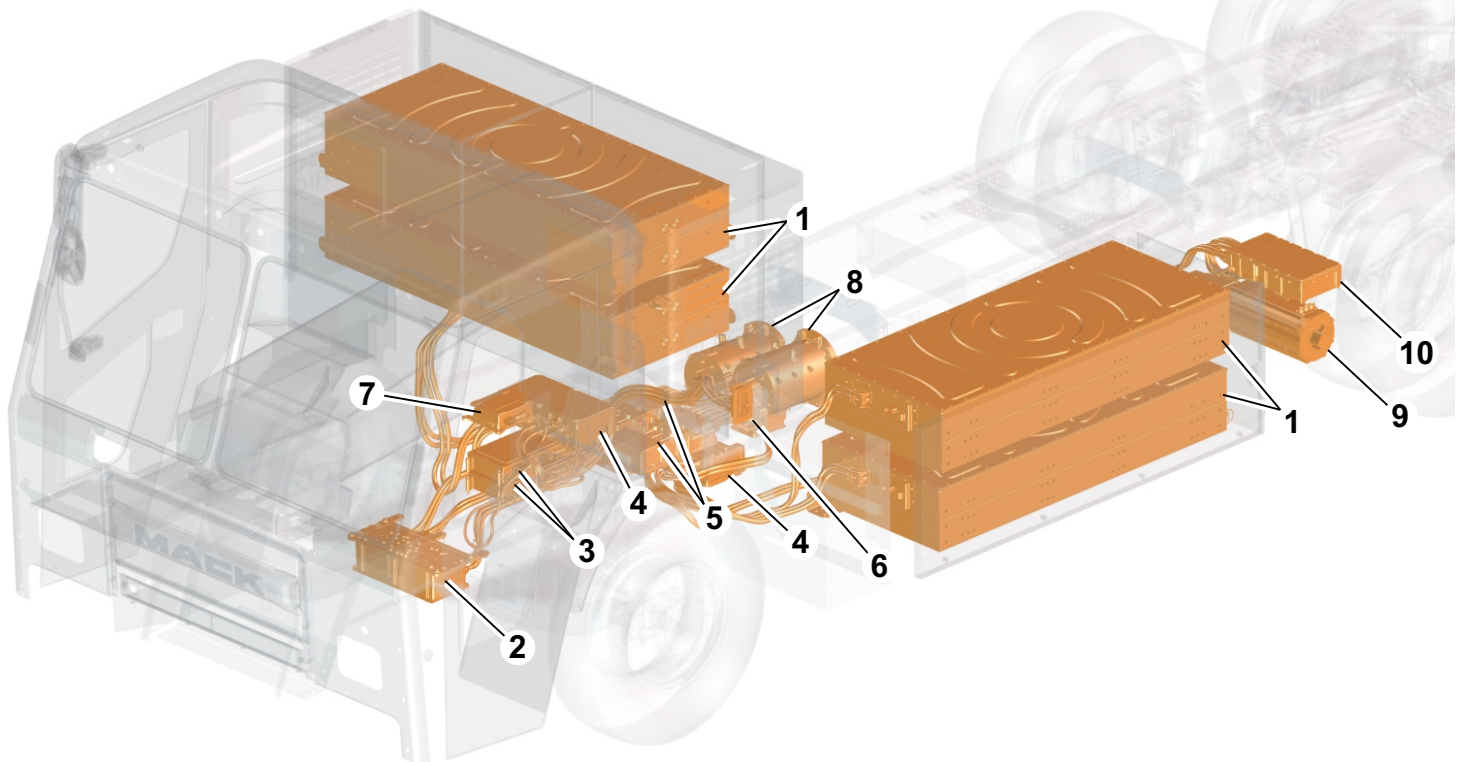

1. Traction Battery: Four Li-ion battery packs supply a maximum of 738V at 110A. Battery electrodes are made of Carbon, Lithium, Nickel, Manganese and Cobalt.

2. Charging switch unit (CSU): The primary function of the Charging Switch Unit (CSU) is to act as a circuit breaker for the charging plug.

3. DC/DC converter: The DC/DC converter converts the traction voltage of 600 V DC to 24 V DC. In electric trucks, the DC/DC converter charges the 12 V batteries and handles the loads connected to the 24 V system.

4. Traction Voltage Junction Box (TVJB): The TVJB has 2 variant combinations depending on the number of high-current and low-current connection interfaces. The TVJB distributes power in the electric propulsion system.

5. Electric Motor Drive (EMD): The EMD converts 600V DC to three-phase AC. The EMD runs the electric motor and controls the speed, torque and calibration.

6. Charging inlet, CCS 1 type : The CCS inlet is used for 600V DC charging. The CCS inlet is equipped with an actuator that prevents accidental disconnection of the charging plug on truck side.

7. Traction Voltage Monitoring Unit (TVMU): The TVMU performs measurements in the traction voltage system, detects any potential hazardous situation and communicates this to the HPCU (Hybrid Powertrain Control Unit).

8. Electric Motor: 2 three-phase AC motors with 400kW to 334 kW capacity power the truck.

9. Electric motor, hydr. ePTO: Three-phase Ac motor with 70kW power the hydraulic pump.

10. Electric Motor Drive (EMD)- hydr. ePTO: The EMD- ePTO converts 600V DC to three-phase AC. The EMD runs the electric motor and controls the speed, torque and calibration.

Identification number

Version number

Page number

800077265

06/2021

7

6. In case of fire



Use a large sustained volume of water to extinguish lithium-ion battery related fire.



If other materials are involved, use class ABC fire extinguisher.



In case of thermal runaway, the lithium-ion batteries can release hydrogen fluoride.

In case of traction battery fire, breather valves (1) may emit large flames as a result of thermal runaway.

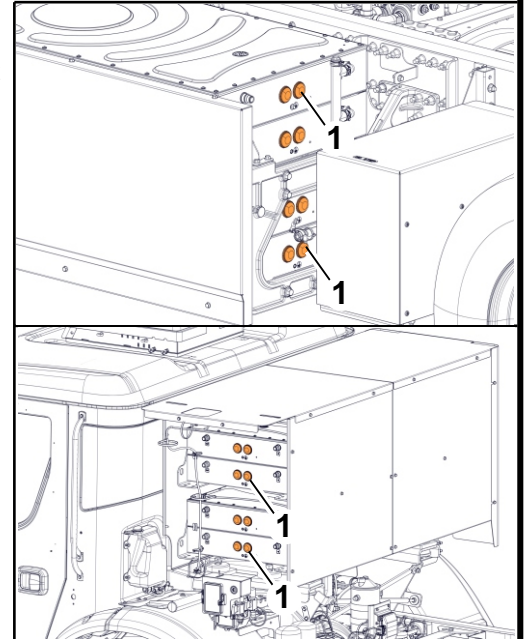

7. In case of water submersion

The damage level of a submerged vehicle may not be visible.



Submersion in water can damage 12 V, 24 V and 600 V components.

Handling a submerged truck without appropriate Personal Protective Equipment (PPE) may result in serious injury or death due to electric shock.

Avoid any contact with the traction voltage cables and electric components.

If possible disable direct hazards (See chapter 3).



8. Towing/transportation/storage



If the traction batteries are damaged, there is a risk of thermal or chemical reaction.



Park the fully electric truck involved in an accident in a suitable place maintaining a safe distance from other vehicles, buildings and combustible objects.

Risk of delayed fire can happen after the fire suppression or if the lithium-ion batteries are damaged.

Observe the truck for a minimum period of 48 hours using a thermal infrared camera.



The electric motors can produce electricity when moving the truck with the rear drive tires on the ground. This remains a potential source of electric shock even when the high voltage system is disabled.

Before towing the truck, it is mandatory to disconnect the drive to the wheels. The drive to the wheels is disabled by either uncoupling the propeller shaft (1) from the driven axle (2) or by removing the axle shafts (3).

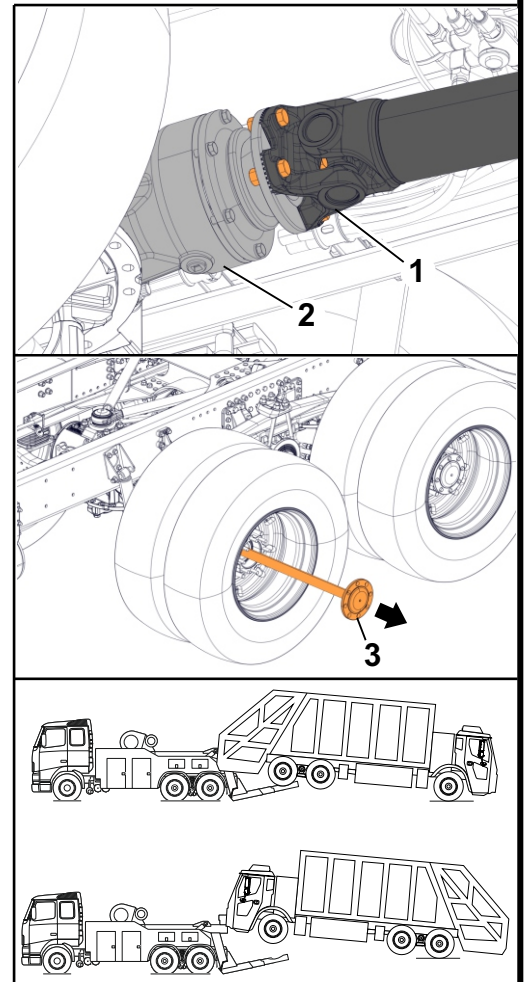

➔ Maximum loading during lifting and towing:

This information specifies the loading which can be applied when using towing hook, towing hitch cross-member, axles and torque stay anchorages.



Single towing hook: Do not load the hook more than the vehicle gross weight.

Double towing hooks: Do not load each hook more than half the vehicle gross weight.

Towing hitch, towing Hitch Cross-Member: Max. 200 mm (7.8 inches) from center of member web

- Lengthways: 20 tons
- Vertically (lift): 7 tons
- Sideways: 17 tons

Note

When the vehicle is towed with the rear suspension lifted, the steering wheel must be locked with the steering lock.

Note

If roof deflectors cannot be removed, tow from the front of vehicle only.

9. Important additional information











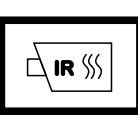

Do not cut any orange cables.

Do not touch any high voltage cables and electric components.

Do not perform any operation on a damaged truck without appropriate Personal Protective Equipment (PPE).

10. Explanation of pictograms used

	Use water to extinguish the fire
	Use ABC powder to extinguish the fire
	General warning sign
	Warning, Electricity
	Use thermal Infrared camera
	To indicate the risk of flammability
	To indicate the risk of an explosion
	To indicate the risk of corrosive material/substances
	Hazardous to the human health
	To indicate the risk of acute toxicity