

## L Series



### About the product

The L20, L18, and L16 Series flush doors are designed to meet the architectural requirements for full flush doors. The L14 Series flush doors are designed to meet the architectural requirements for maximum duty full flush doors. Refer to the Architectural section for specifications and the selection and usage guide of the appropriate door constructions.

This premium door construction combines the strength and dimensional stability of steel with the structural integrity of the laminate core. The continuous bonding of core to steel face sheets provides an attractive, flat door, free of face welding marks. Tests have proven that the L Series door has high resistance to impact damage, low thermal conductivity and high STC ratings.

To meet application, specification and performance requirements, the L Series door offers a wide range of specifiable options including sizes, glass light designs and hardware (mechanical, pneumatic, electrical) preparations.

L Series doors are 1 3/4" (45 mm) thick.

### Installation

1. Installation shall conform to the published Steelcraft installation instructions, ANSI A250.11-2012 *Recommended Erection Instructions for Steel Frames and HMMA 840s*.
2. Fire Rated Assemblies must be in accordance with NFPA Pamphlet 80. The *Authority Having Jurisdiction* is the final authority on issues related to the installation and use of installed Fire Rated Doors.

### Features and benefits

Steelcraft's L Series doors offer the following standard unique features, which enhance long term performance and durability:

1. **Core Systems** that enhance the structural integrity of the door:
  - **Honeycomb (standard):** 1" (25 mm) cell kraft honeycomb configuration that increases structural integrity while reducing overall weight
  - **Polystyrene (optional):** enhanced thermal performance
  - **Polyurethane (optional):** extreme thermal performance
2. **Full Height, Epoxy Filled Mechanical Interlock Edges** provide structural support and stability the full height of the door edges. Available edge options:
  - **Visible Edge Seam (standard):** full height, epoxy filled mechanical interlocked edges
  - **Filled Edge Seam (optional add to standard):** seam filled with structural adhesive and dressed smooth. Includes tack welds above and below edge cutouts as required for doors over 7'2" rated over 20 min
  - **Welded Edge Seam (optional add to standard):** intermittently welded using 1" long welds, then seam filled with structural adhesive and dressed smooth. Option available on L18, L16 and L14 doors.
3. **Universal Hinge Preparations** (patented) allow for easy field conversion from standard weight .134" (3.3 mm) hinges to heavy weight .180" (4.7 mm) hinges.
4. **14 Gauge [0.067" (1.7 mm)] Inverted Top and Bottom Channels** provide stability and protection for the top and bottom edges from abuse.
5. **Beveled Hinge and Lock Edges** allow for tighter installation tolerances, ensure easier operation and eliminate binding and sticking.
6. **Recessed Dezigner™ Glass Trim** provides a clean, neat and flush finish with the door surface.
7. **Factory Applied Baked-On Rust Inhibiting Primer** paint in accordance with ANSI A250.10-2011.

### Specification compliance

1. Door construction for Steelcraft L Series full flush doors meets the requirements of ANSI A250.8-2017.
2. Hardware preparations and reinforcements are in accordance with ANSI A250.6-2003 (R2009). Locations are in accordance with ANSI/DHI A115 unless otherwise stated.

### Fire ratings

L Series doors meet the broadest fire rating requirements. They are listed for installations requiring compliance to both neutral pressure testing (ASTM E152 and UL-10B) and positive pressure standards (UL-10C).

## Doors • L Series

### Rigid Honeycomb

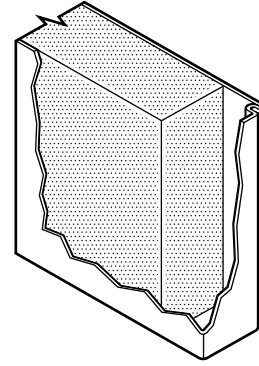
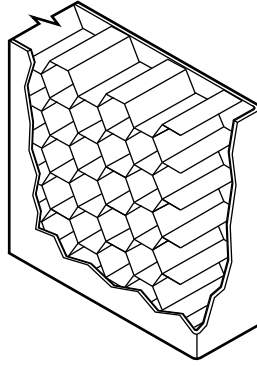

#### Standard Laminated Honeycomb Core

- 1" (25 mm) cell, Kraft honeycomb
- Honeycomb surfaces sanded for maximum adhesion
- Phenol formaldehyde free
- Laminated to both face sheets with contact adhesive
- Assembled door is run through high pressure pinch rollers, achieving ultimate bond

#### Optional cores are polystyrene or polyurethane

#### Optional Polystyrene Core

- 1 pound (453.6g) per ft<sup>3</sup> density slab
- Laminated to both face sheets with contact adhesive
- Labeled applications

#### Optional Polyurethane Core

- 1.8 pound (816.5g) per ft<sup>3</sup> density slab
- Laminated to both face sheets with contact adhesive
- Non-Labeled applications

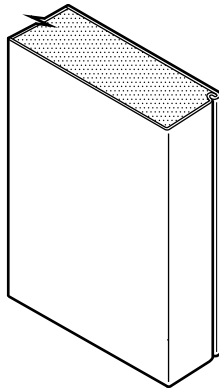

#### Standard Premium Edge Construction

- Beveled hinge & lock edges
- Full height mechanical interlock with epoxy adhesive
- Visible edge seam standard
- Seamless edge optional

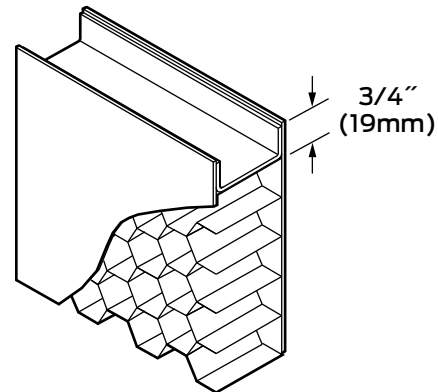

#### Standard Rigid 14 Gauge End Channel Construction

- 14 gauge inverted galvanized top & bottom channels
- Projection welded to both face sheets
- For optional caps, see "[Weather seals](#)" on page 150.

Door application and usage			
Series	Steel Thickness	Opening	Usage Frequency
L20	20 Ga (0.8 mm)	Interior - Cold Rolled Steel	Standard Duty
L20	20 Ga (0.8 mm)	Exterior - Galvanized Steel	
L18	18 Ga (1.0 mm)	Interior - Cold Rolled Steel	Heavy Duty
L18	18 Ga (1.0 mm)	Exterior - Galvanized Steel	
L16	16 Ga (1.3 mm)	Interior - Cold Rolled Steel	Extra Heavy Duty
L16	16 Ga (1.3 mm)	Exterior - Galvanized Steel	
L14	14 Ga (1.7 mm)	Interior - Cold Rolled Steel	Maximum Duty
L14	14 Ga (1.7 mm)	Exterior - Galvanized Steel	Extra Heavy Commercial applications with extremely high use

### Standard hardware preparations

Typical hardware applications shown. Refer to "Hardware" section for more details.

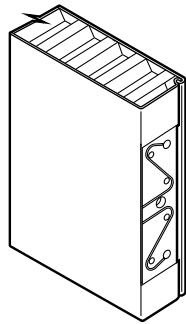

**Universal Mortise Hinge Prep**  
7 Gauge Universal hinge reinforcement

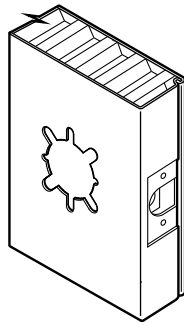

**61L Lock**

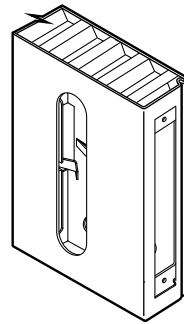

**86 Lock**

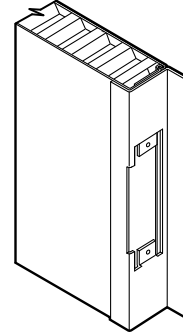

**Inactive Leaf ASA Strike Prep with Astragal attached**

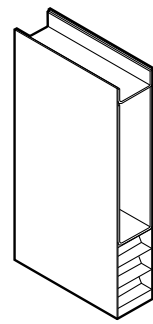

**Optional 14 Gauge Closer Reinforcement**

#### Standard: mortised and reinforced for:

- Patented Universal hinge preparations allow for easy field conversion from standard 4 1/2" (114 mm) x .134" (3.3 mm) standard weight hinges to 4 1/2" (114 mm) x .180" (4.7 mm) heavy weight hinges. Optional hinge preparation for 5" (127 mm) x .146" (3.7 mm) standard weight hinges or for 5" (127 mm) x .190" (4.8 mm) heavy weight hinges is also available.
- A multitude of standard lock preparations are available. The cylindrical 161, 61L and mortise 86 lock preps are the most commonly used active leaf preparations. The 4 7/8" (124 mm) strike prep is the most commonly used inactive leaf preparation.
- Optional reinforcements for surface and concealed Closers are available.
- Special hardware applications are available.

#### Door Sizes and ANSI A250.8 Conversions

Steelcraft product selection for L Series doors has been matched to ANSI/SDI Level and Model designations.

- In accordance with ANSI A250.8-2017, core material is not specific to the level or model designations. Core material selection is specified based on preference and application.
- Recommended minimum frame gauge also applies to the frequency of operation of the opening.

Series	ANSI A250.8			Edge Construction	Edge Maximum Sizes		Recommended Gauge of Frame
	Level	Model	Description		Single	Pair	
<b>Level 1: Light Commercial</b>							
L20	1	1	Full Flush	Visible	3'-0" x 8'-0"	6'-0" x 8'-0"	18 Gauge [0.042" (1.0 mm)]
LF20		2	Seamless	Filled	914 mm x 2438 mm	1829 mm x 2438 mm	16 Gauge [0.053" (1.3 mm)]
<b>Level 2: Heavy Duty Commercial &amp; Institutional</b>							
L18	2	1	Full Flush	Visible	4'-0" x 10'-0" 1219 mm x 3048 mm	8'-0" x 10'-0" 2438 mm x 3048 mm	16 Gauge [0.053" (1.3 mm)]
LF18		2	Seamless	Filled			
LW18		2	Seamless	Welded			
<b>Level 3: Extra Heavy Duty Commercial &amp; Institutional</b>							
L16	3	1	Full Flush	Visible	4'-0" x 10'-0" 1219 mm x 3048 mm	8'-0" x 10'-0" 2438 mm x 3048 mm	16 Gauge [0.053" (1.3 mm)]
LF16		2	Seamless	Filled			
LW16		2	Seamless	Welded			
<b>Level 4: Maximum Duty Commercial &amp; Institutional</b>							
L14	4	1	Full Flush	Visible	4'-0" x 10'-0" 1219 mm x 3048 mm	8'-0" x 10'-0" 2438 mm x 3048 mm	14 Gauge [0.067" (1.7 mm)]
LF14		2	Seamless	Filled			
LW14		2	Seamless	Welded			

## Doors - L Series

### Door edge construction

#### Optional Edge Seams available in the L Series doors:

- **L:** Standard feature includes visible edge seams with full height interlocked edges.
- **LF:** the mechanical edge seam is filled and dressed smooth prior to applying the factory primer.
- **LW:** the mechanical edge seam is welded and dressed smooth prior to applying the factory primer.

#### Standard visible edge seam

##### L Series visible seam features

- Full height mechanical interlock
- Interlock filled with epoxy adhesive
- Visible edge seam

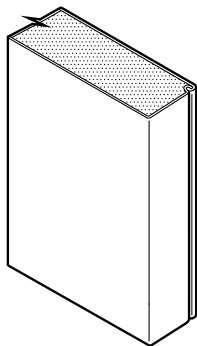

#### Optional seamless edge

##### LF Series Seam Filled Features

- Standard Visible Edge Seam is tack welded above and below edge cutouts as required for doors over 7'2" rated over 20 min
- Edge Seam is then filled with structural adhesive and dressed smooth

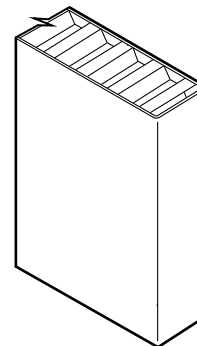

##### LW Series Seam Welded Features

- Standard Visible Edge Seam is intermittently welded using 1" long welds
- Edge Seam is then filled with structural adhesive and dressed smooth
- No visible edge seam

### Glass light options

(Refer to the Lights and Louvers section for further details and options)

#### Designer® Trim

- Standard for 1/4" Thick Glass
- Optional for 1/2" Thick Glass

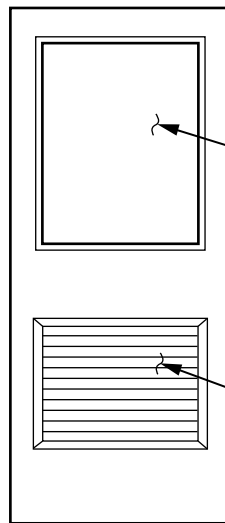
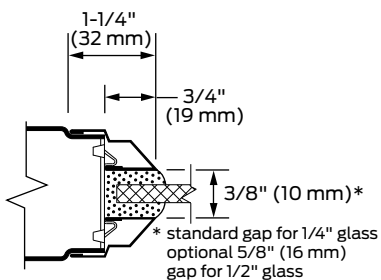

**Note:** Glazing type and thickness vary per job requirements.

**Note:** Louver size and type vary per requirements.

#### Flush Mounted Steel Trim

- For 1" Thick Glass

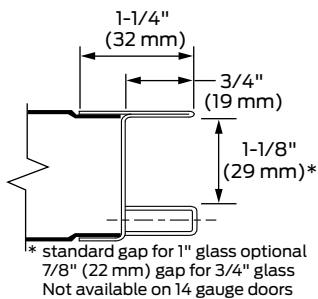

#### Divider Muntins Are Not Available